

SDS120-180 SERIES

AC/DC Single & Multi Output: 120-180 Watts

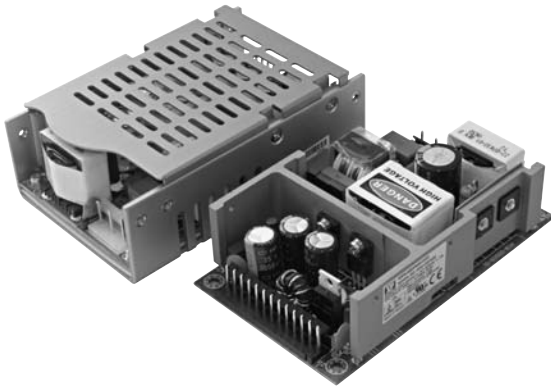

Features

- Convection-cooled
- 3" x 5" Footprint
- Up to 90% Efficiency
- Open Frame, U-Channel & Covered Versions
- Low Temperature Option
- 150 W Medical Version

Specification

Input

Input Voltage	• 90-264 VAC (120-370 VDC)
Input Frequency	• 47-63 Hz
Input Current	• 120 W: 1.7 / 1.0 A at 115 / 230 VAC 150 W: 2.0 / 0.8 A at 115 / 230 VAC 180 W: 2.7 A at 90 VAC
Inrush Current	• 120 W: 20 / 51 A at 115 / 230 VAC 150 W: 54 / 63 A at 115 / 230 VAC 180 W: 54 / 108 A at 115 / 230 VAC
Power Factor	• EN61000-3-2 class A 120 W: EN61000-3-2 class C for loads $\geq 30\%$ 150 W: EN61000-3-2 class C n/a 180 W: EN61000-3-2 class C for loads $\geq 50\%$
Earth Leakage Current	• 120 W: 0.30 / 0.75 mA at 115 / 230 VAC 150 W: 0.40 / 0.75 mA at 115 / 230 VAC 150 W (medical): 0.075 mA at 230 VAC 180 W: 0.75 mA at 230 VAC
Input Protection	• Internal T3.15 A / 250 VAC fuse
No Load Input Power	• 180 W: ≤ 0.5 W

Output

Output Voltage	• See table
Output Voltage Trim	• $\pm 5\%$ output 1 only (3.3 V variant $\pm 10\%$) SDS180: not user adjustable
Initial Set Accuracy	• Single output models: $\pm 1\%$ Multi-output models: $\pm 5\%$
Minimum Load	• No minimum load required for single output models. For multi-output models see table.
Start Up Delay	• 2 s max
Start Up Rise Time	• 2 ms typical
Hold Up Time	• 16 ms minimum at full load and 110 VAC
Line Regulation	• 0.5% typical
Load Regulation	• 3.0% typical
Transient Response	• 4% max deviation, recovery to within 1% in 500 μ s for a 50% load change
Ripple & Noise	• 1% pk-pk typical, 20 MHz bandwidth
Overvoltage Protection	• 112-132% V1 only, recycle input to reset
Overload Protection	• All outputs: 110-150% with auto recovery (primary power limit)
Short Circuit Protection	• Trip & restart (Hiccup mode), auto recovery
Temperature Coefficient	• $\pm 0.04\%/^{\circ}\text{C}$

General

Efficiency	• 120 W: 80% typical 150 W and 180 W: 88% typical
Isolation	• 3000 VAC Input to Output, 1500 VAC Input to Ground, 500 VAC Output to Ground, SDS150-M: 5600 VDC Input to Output, 2800 VDC Input to Ground, 500 VDC Output to Ground
Isolation Resistance	• 50 M
Switching Frequency	• 120 W: PFC 100 kHz typical, PWM 67 kHz typical 150 W: PFC 34 kHz minimum, PWM 55 kHz typical 180 W: PFC 67 kHz typical, PWM 67 kHz typical
Power Density	• 120 W: 4.87 W/In ³ , 150 W: 6.50 W/In ³ 180 W: 7.47 W/In ³
Signals	• Power Fail Detect = TTL active low, combined AC and DC OK signal (option) Warning time 16 ms
MTBF	• >100 kHrs to MIL-HDBK-217F at 25 $^{\circ}\text{C}$, GB

Environmental

Operating Temperature	• 0 $^{\circ}\text{C}$ to +70 $^{\circ}\text{C}$ (-20 $^{\circ}\text{C}$ to +70 $^{\circ}\text{C}$, SDS180), derate linearly from 100% load at +50 $^{\circ}\text{C}$ to 50% load at +70 $^{\circ}\text{C}$, for low temperature option add suffix -L: -40 $^{\circ}\text{C}$ to +70 $^{\circ}\text{C}$, SDS120 and SDS150, not available for SDS150-M and SDS180
Cooling	• Convection-cooled
Operating Humidity	• 5-95% RH, non-condensing
Storage Temperature	• -40 $^{\circ}\text{C}$ to +85 $^{\circ}\text{C}$

EMC & Safety

Emissions	• EN55022, CISPR22 level B conducted SDS150-M: EN55011 class B conducted
Harmonic Currents	• EN61000-3-2 class A 120 W: EN61000-3-2 class C for loads $\geq 30\%$ 150 W: EN61000-3-2 class C n/a 180 W: EN61000-3-2 class C for loads $\geq 50\%$
Voltage Flicker	• EN61000-3-3
ESD Immunity	• EN61000-4-2, level 2 Perf Criteria A
Radiated Immunity	• EN61000-4-3, 3 V/m Perf Criteria A
EFT/Burst	• EN61000-4-4, level 2 Perf Criteria A
Surge	• EN61000-4-5, installation class 3 Perf Criteria A
Conducted Immunity	• EN61000-4-6, level 2 Perf Criteria A
Dips & Interruptions	• EN61000-4-11, 30% 10 ms, 60% 100 ms, >95% 5000 ms Perf Criteria A, B, B
Safety Approvals	• EN60950-1, UL60950-1, CSA60950-1 per cUL. SDS150-M: EN60601-1

Models and Ratings

Max. Power	Output 1				Output 2				Output 3				Model Number ^(2,4,9)
	Vnom	Imin	Imax	Tol. ⁽¹⁾	Vnom	Imin	Imax	Tol. ⁽¹⁾	Vnom	Imin	Imax	Tol. ⁽¹⁾	
72.0 W	3.3 V	0.00 A	22.00 A	5%									SDS120PS03B†^
110.0 W	5.0 V	0.00 A	22.00 A	5%									SDS120PS05B†^
115.0 W	7.0 V	0.00 A	16.42 A	5%									SDS120PS07B
120.0 W	9.0 V	0.00 A	13.33 A	4%									SDS120PS09B
120.0 W	12.0 V	0.00 A	10.00 A	3%									SDS120PS12B†^
120.0 W	15.0 V	0.00 A	8.00 A	3%									SDS120PS15B†^
120.0 W	18.0 V	0.00 A	6.66 A	3%									SDS120PS18B
120.0 W	24.0 V	0.00 A	5.00 A	2%									SDS120PS24B†^
120.0 W	28.0 V	0.00 A	4.28 A	2%									SDS120PS28B†^
120.0 W	36.0 V	0.00 A	3.33 A	2%									SDS120PS36B
120.0 W	48.0 V	0.00 A	2.50 A	2%									SDS120PS48B†^
79.5 W	3.3 V	1.50 A	15.00 A	5%	5.0 V	0.40 A	6.0 A	5%					SDS120PD00B
120.0 W	3.3 V	1.50 A	15.00 A	5%	12.0 V	0.20 A	6.0 A	5%					SDS120PD01B
120.0 W	5.0 V	1.50 A	15.00 A	5%	12.0 V	0.20 A	6.0 A	5%					SDS120PD02B
120.0 W	5.0 V	1.50 A	15.00 A	5%	15.0 V	0.20 A	6.0 A	5%					SDS120PD03B
120.0 W	5.0 V	1.50 A	15.00 A	5%	24.0 V	0.10 A	3.5 A	5%					SDS120PD04B
120.0 W	5.0 V	1.50 A	15.00 A	5%	-24.0 V	0.20 A	2.0 A	5%					SDS120PD05B
120.0 W	28.0 V	0.39 A	3.92 A	5%	5.0 V	0.20 A	2.0 A	5%					SDS120PD06B
91.5 W	3.3 V	1.50 A	15.00 A	5%	5.0 V	0.60 A	6.0 A	5%	12.0 V	0.00 A	1.0 A	5%	SDS120PT00B†^
91.5 W	3.3 V	1.50 A	15.00 A	5%	5.0 V	0.60 A	6.0 A	5%	-12.0 V	0.00 A	1.0 A	5%	SDS120PT01B
120.0 W	3.3 V	1.50 A	15.00 A	5%	12.0 V	0.60 A	6.0 A	5%	5.0 V	0.00 A	0.8 A	5%	SDS120PT02B
120.0 W	3.3 V	1.50 A	15.00 A	5%	12.0 V	0.60 A	6.0 A	5%	-5.0 V	0.00 A	0.8 A	5%	SDS120PT03B
120.0 W	3.3 V	1.50 A	15.00 A	5%	12.0 V	0.60 A	6.0 A	5%	-12.0 V	0.00 A	0.8 A	5%	SDS120PT04B
120.0 W	3.3 V	1.50 A	15.00 A	5%	12.0 V	0.60 A	6.0 A	5%	12.0 V	0.00 A	0.8 A	5%	SDS120PT05B
120.0 W	5.0 V	1.50 A	15.00 A	5%	12.0 V	0.60 A	6.0 A	5%	5.0 V	0.00 A	0.8 A	5%	SDS120PT06B
120.0 W	5.0 V	1.50 A	15.00 A	5%	12.0 V	0.60 A	6.0 A	5%	-5.0 V	0.00 A	0.8 A	5%	SDS120PT07B†^
120.0 W	5.0 V	1.50 A	15.00 A	5%	12.0 V	0.60 A	6.0 A	5%	-12.0 V	0.00 A	0.8 A	5%	SDS120PT08B†^
120.0 W	5.0 V	1.50 A	15.00 A	5%	12.0 V	0.60 A	6.0 A	5%	12.0 V	0.00 A	0.8 A	5%	SDS120PT09B
120.0 W	5.0 V	1.50 A	15.00 A	5%	15.0 V	0.60 A	6.0 A	5%	-15.0 V	0.00 A	0.8 A	5%	SDS120PT10B†^
120.0 W	5.0 V	1.50 A	15.00 A	5%	15.0 V	0.60 A	6.0 A	5%	15.0 V	0.00 A	0.8 A	5%	SDS120PT11B
120.0 W	5.0 V	1.50 A	15.00 A	5%	24.0 V	0.35 A	3.5 A	5%	-24.0 V	0.00 A	0.8 A	5%	SDS120PT12B
120.0 W	5.0 V	1.50 A	15.00 A	5%	24.0 V	0.35 A	3.5 A	5%	24.0 V	0.00 A	0.8 A	5%	SDS120PT13B
120.0 W	5.0 V	1.50 A	15.00 A	5%	24.0 V	0.35 A	3.5 A	5%	-12.0 V	0.00 A	0.8 A	5%	SDS120PT14B
120.0 W	5.0 V	1.50 A	15.00 A	5%	24.0 V	0.35 A	3.5 A	5%	12.0 V	0.00 A	0.8 A	5%	SDS120PT15B†
120.0 W	5.0 V	1.50 A	15.00 A	5%	10.0 V	0.60 A	6.0 A	5%	-10.0 V	0.00 A	1.0 A	5%	SDS120PT16B
120.0 W	5.0 V	1.50 A	15.00 A	5%	10.0 V	0.60 A	6.0 A	5%	10.0 V	0.00 A	1.0 A	5%	SDS120PT17B

Notes

- Total regulation includes line regulation and load regulation.
- For optional PCB only version, delete suffix 'B' from model number. Example SDS120PS03.
- For non-standard voltages contact sales.
- For optional low temperature -40 ° C operation, add suffix '-L' to model number. Example: SDS120PS12B-L
- For optional Power Fail Detect circuit, add suffix '-P' to model number, example: SDS120PS12B-P

Mechanical Details

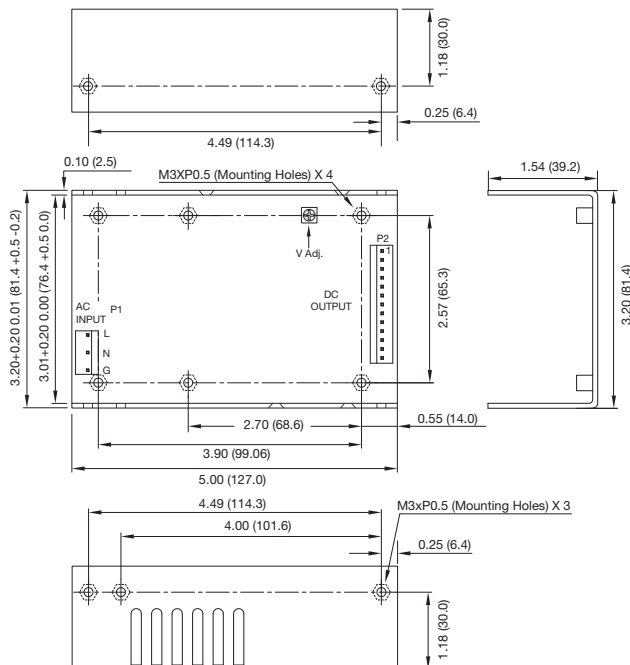

All dimensions are in inches (mm).
 Weight: 0.77-0.99 lbs (350-450 g) approx.
 For PCB-only version, overall dimensions are max 5.00 x 3.00 x 1.44 (127.0 x 76.2 x 36.6).

Pin	PIN CONNECTIONS		
	Single	Dual	Triple
1	V1	V2	V2
2	V1	V2	V2
3	V1	V1	V1
4	V1	V1	V1
5	V1	V1	V1
6	V1	V1	V1
7	Return	Common	Common
8	Return	Common	Common
9	Return	Common	Common
10	Return	N/C	V3
11	Return	Common	Common
12	Return	Common	Common
13	PFD ⁽¹⁾	PFD ⁽¹⁾	PFD ⁽¹⁾

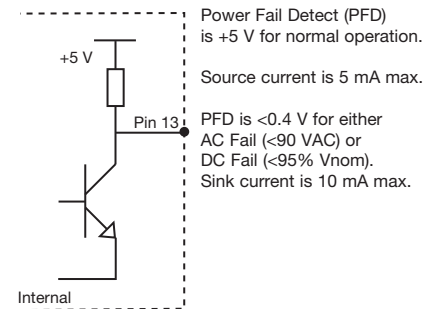

Notes:

- Optional Power Fail Detect signal on 'P' versions only. Standard models pin 13 is N/C.
- I/P connector P1 mates with Molex housing 09-50-3051 & Molex 2878 series crimp terminal.
- O/P P2 mates with Molex housing 09-50-3131 & Molex 2878 series crimp terminal.
- For optional cover kit order part number SDS120 COVER†^, to receive unit with cover fitted add suffix '-C' to model number, e.g. SDS120PS12B-C (overall height is 1.73 (44.0)).
- For mating connector kit order part number SDS120 CON KIT†.
- For cable harness order part number SDS120S LOOM† for single output models & SDS120M LOOM† for multi-output models.
- Maximum mounting screw penetration: 0.16 (4.0)

Maximum Output Power	Output Voltage	Output Current		Total Regulation ⁽¹⁾	Model Number ^(2,4,5,6)
		Minimum	Maximum		
144 W	9 V	0 A	16.00 A	5%	SDS150PS09B†^
150 W	12 V	0 A	12.50 A	5%	SDS150PS12B†^
150 W	15 V	0 A	10.00 A	5%	SDS150PS15B†^
150 W	18 V	0 A	8.33 A	4%	SDS150PS18B†^
150 W	24 V	0 A	6.25 A	3%	SDS150PS24B†^
150 W	30 V	0 A	5.00 A	2%	SDS150PS30B
150 W	36 V	0 A	4.17 A	2%	SDS150PS36B
150 W	48 V	0 A	3.13 A	2%	SDS150PS48B†^

Notes

- Total regulation includes line regulation and load regulation.
- For optional 2 pin Molex input, add suffix '-D' to model number. Example SDS150PS12B-D.
- For non-standard voltages contact sales.
- For optional low temperature -40 ° C operation, add suffix '-L' to model number. Example: SDS150PS12B-L
- For optional PCB only version, delete suffix 'B' from model number. Example SDS150PS48.
- For optional Power Fail Detect signal (PFD), add suffix '-P' to model number. Example: SDS150PS48B-P.

Mechanical Details

U Channel

Weight: 1.27 lbs (580 g) approx.

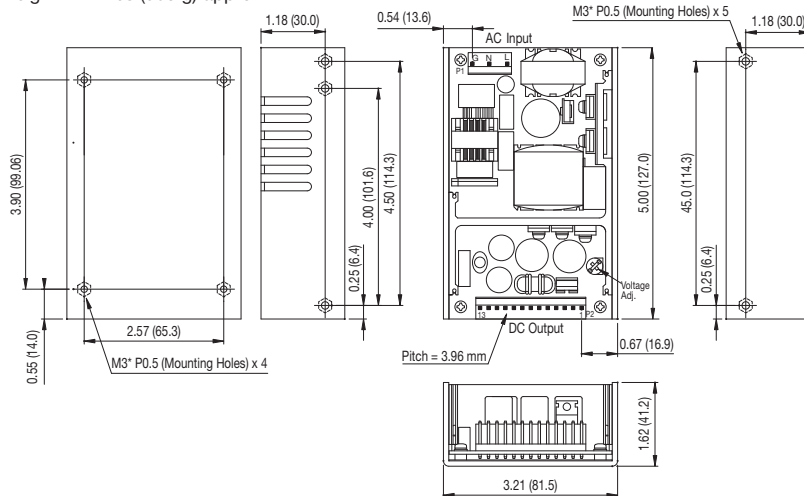

P2 - PIN CONNECTIONS			
Pin	Function	Pin	Function
1	V1	7	Return
2	V1	8	Return
3	V1	9	Return
4	V1	10	Return
5	V1	11	Return
6	V1	12	Return
		13	PFD ⁽⁷⁾

Notes:

- Dimensions in inches (mm), tolerance ± 0.02 (± 0.5).
- Input connector P1 mates with Molex housing 09-50-3051 and Molex 2478 series crimp terminal.
- Output connector P2 mates with Molex housing 09-50-3131 and Molex 2478 series crimp terminal.
- Optional power fail detect signal on 'P' versions only. Standard models pin 13 is not connected.
- For mating connector kit order part number SDS150 CON KIT.
- For cable harness order part number SDS150 LOOM.
- Maximum mounting screw penetration: 0.16 (4.0)
- For optional cover kit order part number SDS150 COVER

Open Frame

Weight: 0.86 lbs (390 g) approx.

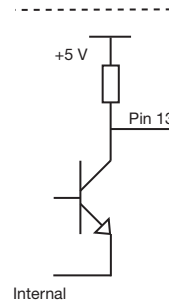
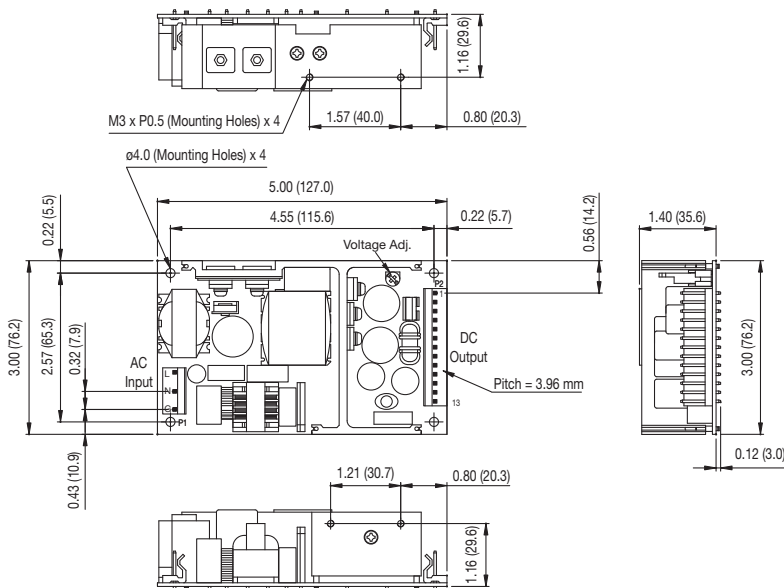

Power Fail Detect (PFD) is +5 V for normal operation.

Source current is 5 mA max.

PFD is <0.4 V for either AC Fail (<90 VAC) or DC Fail (<95% Vnom). Sink current is 10 mA max.

Maximum Output Power	Output Voltage	Output Current		Total Regulation ⁽²⁾	Model Number ^(4,5)
		Minimum	Maximum		
150 W ⁽¹⁾	12 V	0 A	12.5 A	5%	SDS150PS12B-M
150 W ⁽²⁾	24 V	0 A	6.25 A	5%	SDS150PS24B-M

Notes

- Output power is 150 W at highline input and 130 W at lowline input (90-132 VAC).
- Output power decrease linearly from 150 W at 100 VAC input to 135 W at 90 VAC input.
- Total regulation includes line regulation and load regulation.
- For optional PCB only version delete suffix 'B' from part number.
Example SDS150PS12-M.
- For optional 2 pin Molex input, add suffix '-D' to model number.
Example SDS150PS12-MD.
- For non-standard voltages contact sales.

Mechanical Details

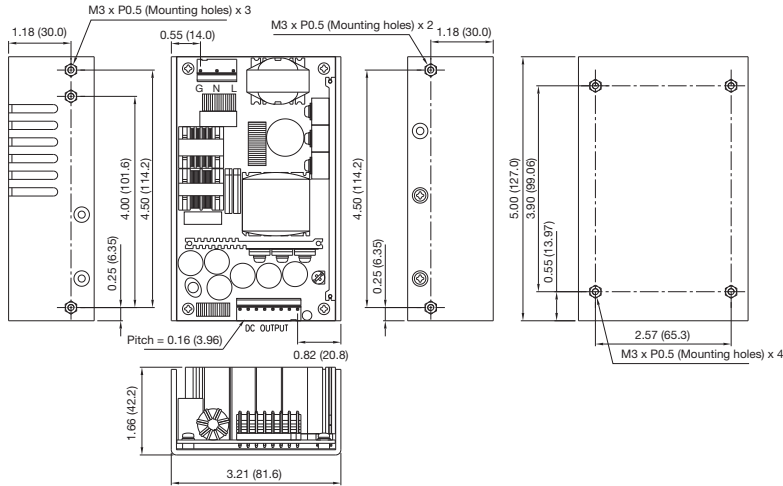

P2 - PIN CONNECTIONS			
Pin	Function	Pin	Function
1	V1	5	Return
2	V1	6	Return
3	V1	7	Return
4	V1	8	Return

Notes:

- Dimensions in inches (mm), tolerance ± 0.02 (± 0.5).
- Weight: 1.27 lbs (580 g)
- Input connector P1 mates with Molex housing 09-50-3051 and Molex 2478 series crimp terminal.
- Output connector P2 mates with Molex housing 09-50-3081 and Molex 2478 series crimp terminal.
- For mating connector kit order part number: SDS150-M CON KIT.
- For cable harness order part number SDS150-M LOOM.

Models and Ratings

Maximum Output Power	Output Voltage	Output Current		Total Regulation ⁽²⁾	Model Number ⁽³⁾
		Minimum	Maximum		
170 W ⁽¹⁾	12 V	0 A	14.16 A	5%	SDS180PS12B
180 W	24 V	0 A	7.50 A	3%	SDS180PS24B
180 W	48 V	0 A	3.75 A	2%	SDS180PS48B

Notes

- Output power is 170 W at highline input and 160 W at low line input, (90-132 VAC).
- Total regulation includes line regulation and load regulation.
- For optional L-bracket version, delete suffix 'B' from model number.
Example SDS180PS48.
- For non-standard voltages contact sales.

Mechanical Details

U Channel

Weight: 1.14 lbs (520 g)

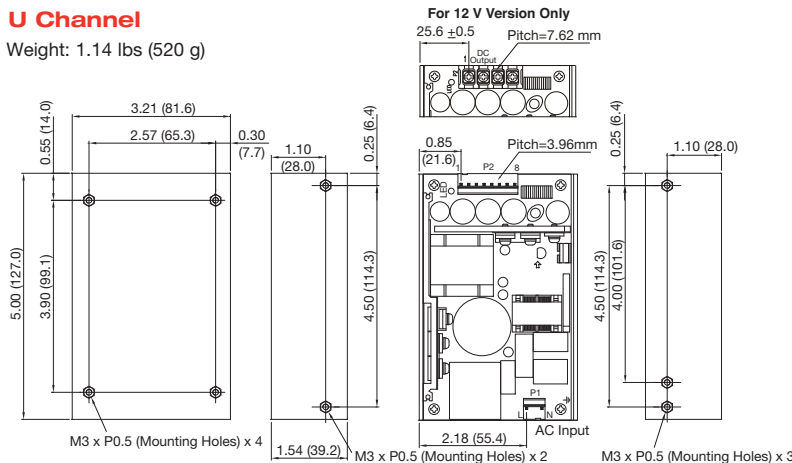

L-bracket

Weight: 1.06 lbs (480 g)

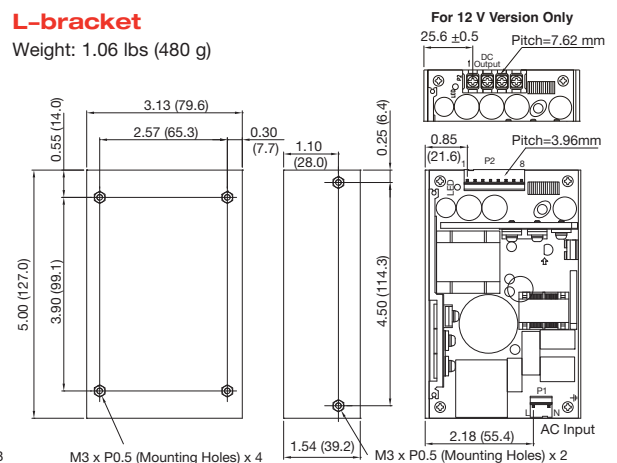

P2 - PIN CONNECTIONS for 24/48 V versions			
Pin	Function	Pin	Function
1	Return	5	V1
2	Return	6	V1
3	Return	7	V1
4	Return	8	V1

Notes:

- Dimensions in inches (mm), tolerance ± 0.02 (± 0.5).
- Input connector P1 mates with Molex housing 09-50-3031 and Molex 2478 series crimp terminal.
- Output connector P2 mates with Molex housing 09-50-3061 (or 09-50-3081) and Molex 2478 series crimp terminal for 24/48 V Versions.
For 12 V Version, output terminal is screw terminal.
- For mating connector kit order part number: SDS180 CON KIT.
- For cable harness order part number SDS180 LOOM.
- Maximum mounting screw penetration: 0.16 (4.0)