

ECS25-60 SERIES

AC/DC Single Output: 25 - 60 Watts

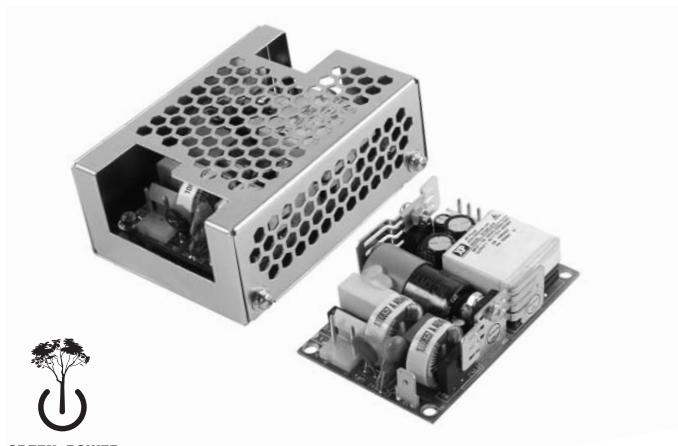

GREEN-POWER

Specification

Input

Input Voltage	• 80-264 VAC (120-370 VDC), derate linearly from 100% at 90 VAC to 80% at 80 VAC
Input Frequency	• 47-400 Hz ⁽¹⁾
Input Current	• 25 W: 0.45 A, 45 W: 0.75 A, 60 W: 0.95 A typical at 115 VAC, full load, 25 W: 0.30 A, 45 W: 0.45 A, 60 W: 0.60 A, typical at 230 VAC, full load
Inrush Current	• 40 A max at 230 VAC, cold start 25 °C
Power Factor	• EN61000-3-2, class A
No Load Input Power	• US05, 12 & 24 models: <0.3 W, US48 and all ECS60 models: <0.5 W
Earth Leakage Current	• 260 µA at 264 VAC/60 Hz max, 80/160 µA typical 115/230 VAC
Input Protection	• T3.15 A/250 V internal fuse in line and neutral

Output

Output Voltage	• 5-48 VDC (see tables)
Output Voltage Trim	• ±10%
Initial Set Accuracy	• ±1%
Minimum Load	• No minimum load required
Start Up Delay	• 1 s typical
Start Up Rise Time	• 50 ms
Hold Up Time	• 16 ms min at 115 VAC
Drift	• ±0.2% after 20 min warm up
Line Regulation	• ±0.5% max
Load Regulation	• ±1%
Over/Undershoot	• 5% typical
Transient Response	• 4% max. deviation, recovery to within 1% in 500 µs for a 50-75-50% load change
Ripple & Noise	• 1% pk-pk V1, 20 MHz bandwidth ⁽²⁾
Overvoltage Protection	• 115-140% Vnom, recycle input to reset
Overload Protection	• 110-160%
Short Circuit Protection	• Continuous trip and restart (hiccup mode)
Temperature Coefficient	• 0.05%/°C

Notes

1. Safety approvals cover frequency 47-63 Hz.
2. ECS60US12 1.5% pk-pk, 20 MHz bandwidth under certain line/load conditions.
3. See longform datasheet or contact sales for details.

Features

- IT & Medical Safety Approvals
- Very Small 2" x 3" x 0.95" Package
- <0.3 W No Load Input Power
- 25, 45 & 60 W – Convection Cooled Ratings
- Class I & Class II Installations
- -20 °C to +70 °C Operation

General

Efficiency	• Up to 90%, model dependant
Isolation	• 4000 VAC Input to Output, 1500 VAC Input to Ground, 500 VDC Output to Ground
Switching Frequency	• 65 KHz typical
Power Density	• Up to 7.9 W/in ³
MTBF	• 25 & 45 W: 1072 kHrs, 60 W: 471 kHrs to MIL-HDBK-217F at 25 °C, GB

Environmental

Operating Temperature	• -20 °C to +70 °C derate linearly from +50 °C at 2.5%/°C to 50% load at +70 °C.
Cooling	• Convection, see thermal considerations
Operating Humidity	• 95% RH, non-condensing
Storage Temperature	• -40 °C to +85 °C
Operating Altitude	• 3000 m
Shock	• 30 g pk, half sine, 6 axes
Vibration	• 2 g rms, 5 Hz to 500 kHz, 3 axes

EMC & Safety

Low Voltage PSU EMC Emissions	• EN61204-3, high severity level • All models: EN55011/22 level B conducted, 45 & 60 W: EN55011/22 level A radiated, ECS25 & some ECS60 models: level B radiated ⁽³⁾
Harmonic Currents	• EN61000-3-2, class A
Voltage Flicker	• EN61000-3-3
Radiated Immunity	• EN61000-4-3, level 3 Perf Criteria A
EFT/Burst	• EN61000-4-4, level 3 Perf Criteria A
Surge	• EN61000-4-5, installation class 3 Perf Criteria A
Conducted Immunity	• EN61000-4-6, level 3 Perf Criteria A
Dips & Interruptions	• EN61000-4-11, 30% 10 ms, 60% 100 ms, 100% 5000 ms, Perf Criteria A, B, B, EN60601-1-2, 30% 500 ms, 60% 100 ms, 100% 10 ms, 100% 5000 ms, Perf Criteria A, A, A, B - 230 VAC. Consult longform datasheet for 115 V operation.
Safety Approvals	• IEC60950-1 CB report, UL60950-1, TUV EN60950-1, IEC60601-1 CB report, UL60601-1, TUV 60601-1
Equipment Protection Class	• Class I and Class II

Models and Ratings

ECS25 XP

Output Power	Output Voltage	Output Current	Model Number ⁽¹⁾
25 W	12.0 VDC	2.08 A	ECS25US12†^
25 W	15.0 VDC	1.67 A	ECS25US15†^
25 W	24.0 VDC	1.04 A	ECS25US24†^
25 W	48.0 VDC	0.52 A	ECS25US48†^

Notes

1. For covered versions, add suffix '-C' to model number or order part number ECS25-60 COVER KIT for standalone cover. Not suitable for use in class II installations, derate output power by 20% with cover.

Mechanical Details

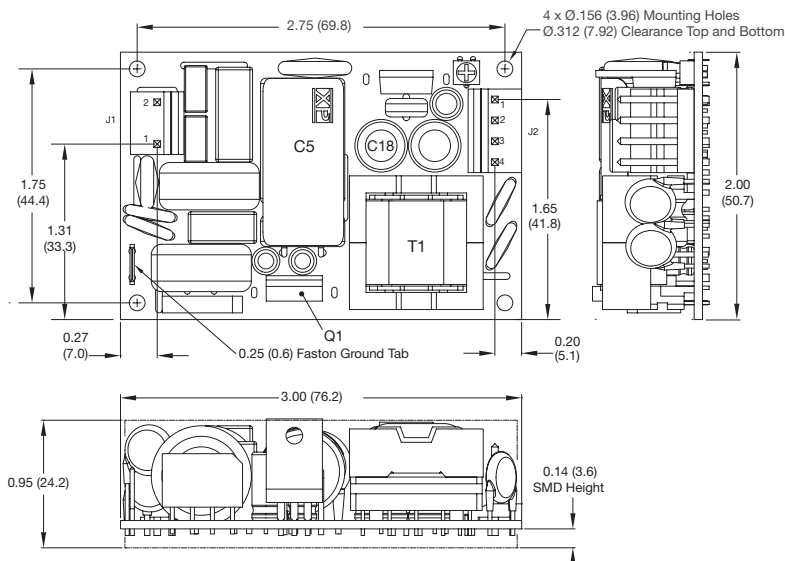

Input Connector J1 Molex PN 09-65-2038	
Pin 1	Line
Pin 2	Neutral
0.25" Faston	Earth

Output Connector J2 Molex PN 09-65-2048	
Pin 1	+V1
Pin 2	+V1
Pin 3	RTN
Pin 4	RTN

J1 mates with Molex Housing PN 09-50-1031, J2 mates with Molex Housing PN 09-50-1041 and both with Molex Series 5194 Crimp Terminals

Notes

- All dimensions in inches (mm).
Tolerance .xx = ±0.02 (0.50); .xxx = ±0.01 (0.25)
- Weight 0.22 lbs (100 g)

Covered version (All ECS25-60 Models)

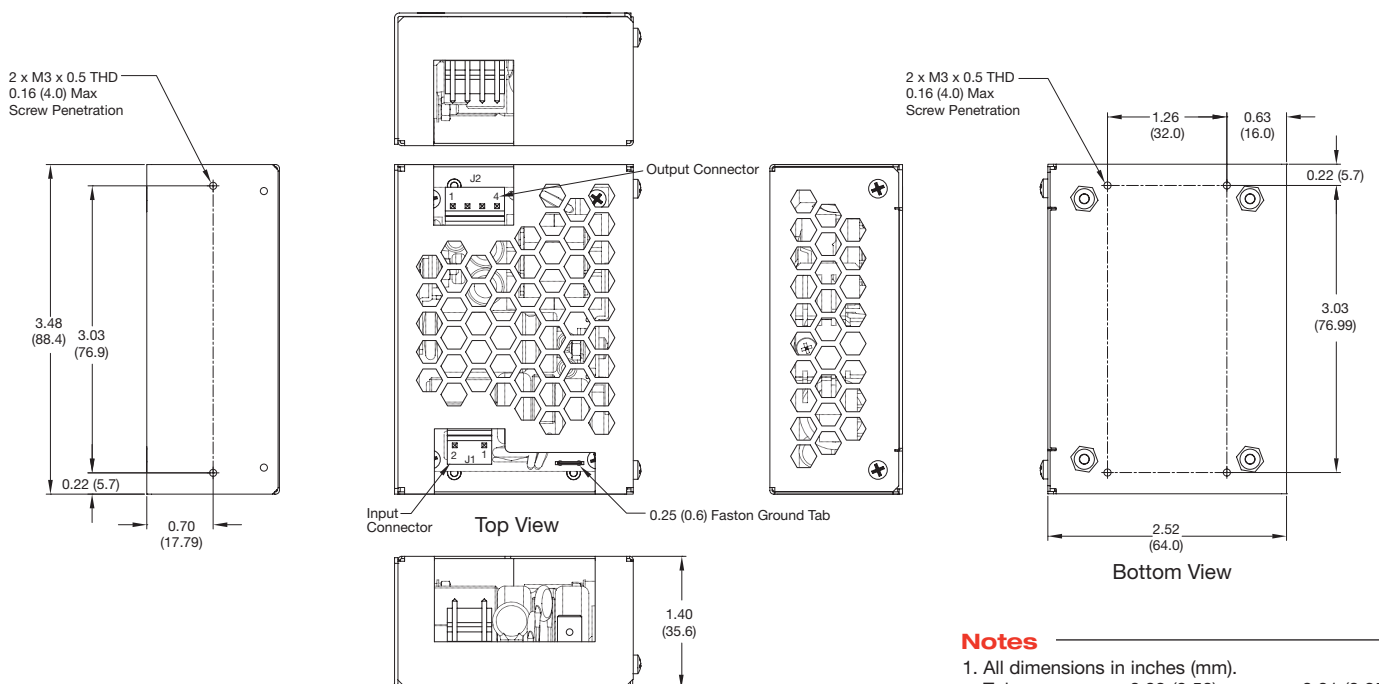

Notes

- All dimensions in inches (mm).
Tolerance .xx = ±0.02 (0.50); .xxx = ±0.01 (0.25)
- Weight 0.5 lbs (230 g)

Output Power	Output Voltage	Output Current	Model Number ⁽¹⁾
30 W	5.0 VDC	6.00 A	ECS45US05†^
45 W	12.0 VDC	3.75 A	ECS45US12†^
45 W	15.0 VDC	3.00 A	ECS45US15†^
45 W	24.0 VDC	1.90 A	ECS45US24†^
45 W	48.0 VDC	0.95 A	ECS45US48†^

Notes

1. For covered versions, add suffix '-C' to model number or order part number ECS25-60 COVER KIT for standalone cover. Not suitable for use in class II installations, derate output power by 20% with cover.

Price & Stock Enquiry

Mechanical Details

5 V version

Input Connector J1 Molex PN 09-65-2038	
Pin 1	Line
Pin 2	Neutral
0.25" Faston	Earth

Output Connector J2 Molex PN 09-65-2048	
Pin 1	+V1
Pin 2	+V1
Pin 3	RTN
Pin 4	RTN

J1 mates with Molex Housing PN 09-50-1031,
J2 mates with Molex Housing PN 09-50-1041 and both with Molex Series 5194 Crimp Terminals

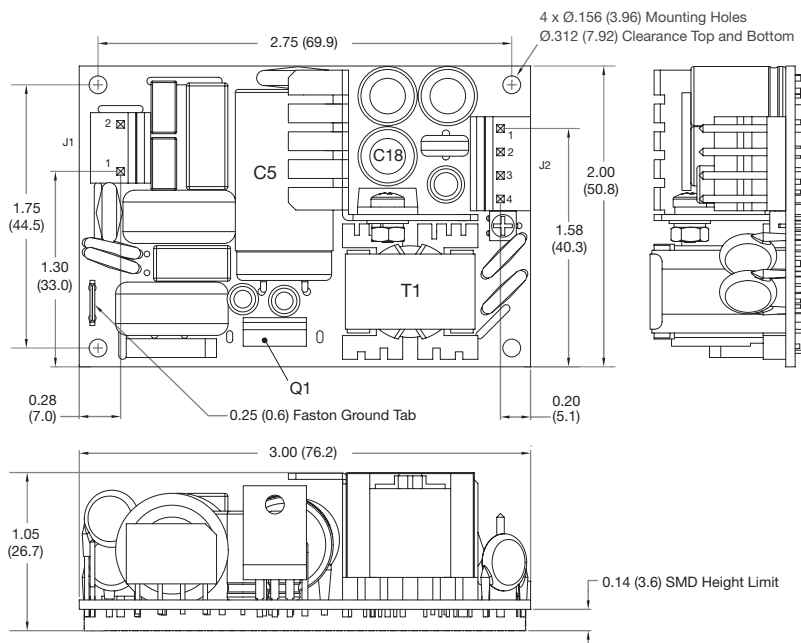

12-48 V version

Input Connector J1 Molex PN 09-65-2038	
Pin 1	Line
Pin 2	Neutral
0.25" Faston	Earth

Output Connector J2 Molex PN 09-65-2048	
Pin 1	+V1
Pin 2	+V1
Pin 3	RTN
Pin 4	RTN

J1 mates with Molex Housing PN 09-50-1031,
J2 mates with Molex Housing PN 09-50-1041 and both with Molex Series 5194 Crimp Terminals

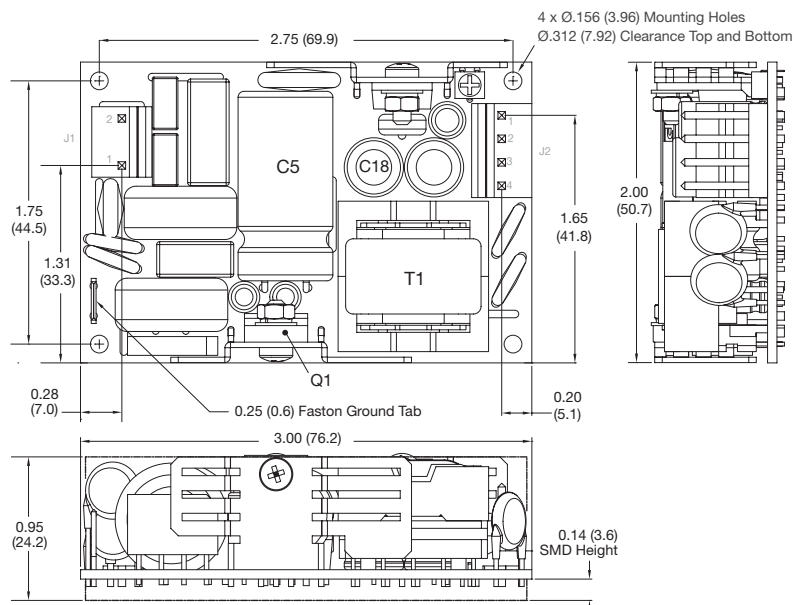

Notes

1. All dimensions in inches (mm).
Tolerance .xx = ±0.02 (0.50); .xxx = ±0.01 (0.25)

2. Weight 0.22 lbs (100 g)

Output Power	Output Voltage	Output Current	Model Number ⁽¹⁾
40 W	5.0 VDC	8.00 A	ECS60US05 ⁽²⁾
60 W	12.0 VDC	5.00 A	ECS60US12†^
60 W	15.0 VDC	4.00 A	ECS60US15†^
60 W	24.0 VDC	2.50 A	ECS60US24†^
60 W	48.0 VDC	1.25 A	ECS60US48†^

Notes

- For covered versions, add suffix '-C' to model number or order part number ECS25-60 COVER KIT for standalone cover. Not suitable for use in class II installations, derate output power by 20% with cover.
- ECS60US05 available Q3 2011.

Price & Stock Enquiry

Mechanical Details

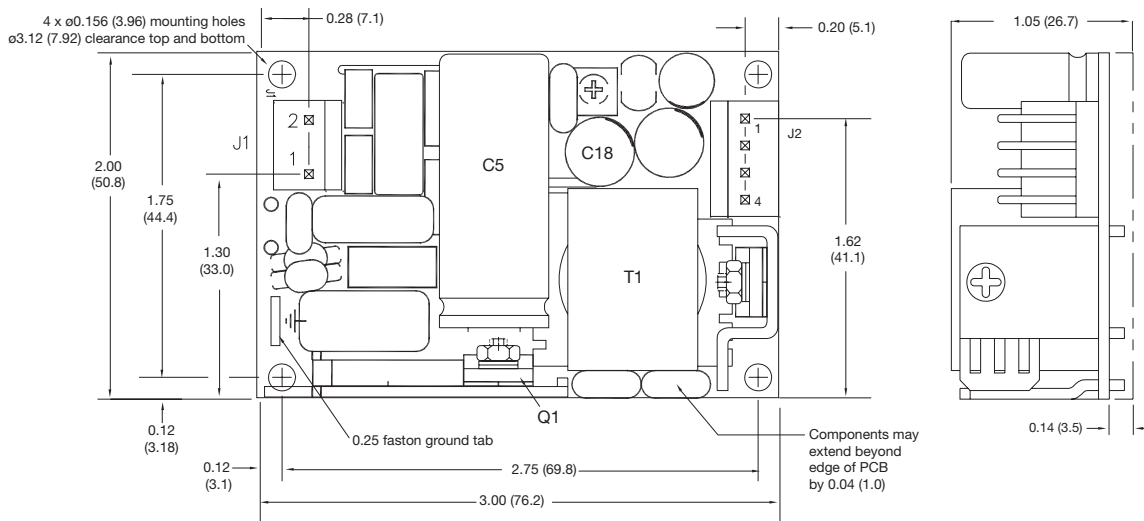

Input Connector J1 Molex PN 09-65-2038	
Pin 1	Line
Pin 2	Neutral
0.25" Faston	Earth

J1 mates with Molex Housing PN 09-50-1031

Output Connector J2 Molex PN 09-65-2048	
Pin 1	+V1
Pin 2	+V1
Pin 3	RTN
Pin 4	RTN

J2 mates with Molex Housing PN 09-50-1041 and both with Molex Series 5194 Crimp Terminals

Notes

- All dimensions in inches (mm).
Tolerance .xx = ±0.02 (0.50); .xxx = ±0.01 (0.25)
- Weight: 0.22 lbs (100 g)

Thermal Considerations (All ECS25-60 Models)

In order to ensure safe and reliable operation of the PSU in the most adverse conditions permitted in the end-use equipment, the temperature of the components listed in the table must not be exceeded. See mechanical drawings for component locations. Temperature should be monitored using K type thermocouples placed on the hottest part of the component (out of any direct air flow).

Temperature Measurements (Ambient ≤50 °C)	
Component	Max Temperature ° C
T1	110 °C
Q1	110 °C
C5	100 °C
C18	100 °C