

UP

ZERO-UP 200W/400W/800W
Programmable DC Power Supplies
Constant Voltage/Constant Current

*Built-in RS232 & RS485 Interface
with GPIB option.*



USER'S MANUAL

DECLARATION OF CONFORMITY

We Nemic-Lambda Ltd., located at Karmiel Industrial Zone, Israel, declare under our sole responsibility that the product:

Product Name: Programmable Regulated Power Supplies, ZUP Series

Models:	ZUP6-33	ZUP6-66	ZUP6-132
	ZUP10-20	ZUP10-40	ZUP10-80
	ZUP20-10	ZUP20-20	ZUP20-40
	ZUP36-6	ZUP36-12	ZUP36-24
	ZUP60-3.5	ZUP60-7	ZUP60-14

Conforms to the following product specifications:

Safety: EN61010-1/04.93, EN61010-1 A2/07.95
UL3111-1

Electromagnetic Emissions:

EN55011:1991 Conducted Emissions: Class B

Radiated Emissions: Class A

IEC1000-4-2:1995 4.0KV CD, 4.0KV AD

IEC1000-4-3:1995 3V/m

IEC1000-4-4:1995 1.0KV AC Power Lines
0.5KV Communication Lines

IEC1000-4-5:1995 2.0KV AC Power Lines
1.0KV AC to Ground
1.0KV Communication Lines

IEC1000-4-6:1996 3V

IEC1000-4-11:1994

IEC1000-3-2:1995 Class A

IEC1000-3-3:1995

The product herewith complies with the requirements of the Low Voltage Directive 73/23/EEC and the EMC directive 89/336/EEC for Electrical Equipment used in Measurement Control and Laboratory environments, and carries the CE mark accordingly.

Our importer to the EU is Coutant Lambda Limited, located at Kingsley Avenue, Ilfracombe, Devon EX34 8ES, UK. Further, all products covered by this declaration are manufactured by processes which ensure continued compliance of the products with the requirements of the Low voltage and the EMC directives.

Name of Authorized Signatory: Adam Pawicz-Szczerbo

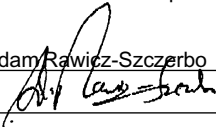
Signature of Authorized Signatory: 

Position of Authorized Signatory: Managing Director, Coutant Lambda

Date: 26 April 1995

Place where signed: Ilfracombe, UK

TABLE OF CONTENTS: ZUP SERIES

WARRANTY	pg. 1
SAFETY INSTRUCTIONS	pg. 2
CHAPTER 1. General Information	pg. 5
1.1 User manual content	
1.2 Introduction	
1.2.1 General description	
1.2.2 Configurations	
1.2.3 Control via the serial communication port	
1.2.4 Output connections	
1.2.5 Analog voltage programming	
1.2.6 Parallel operation	
1.2.7 Cooling and mechanical construction	pg. 6
1.3 Accessories	
1.3.1 General	
1.3.2 Serial link cables	
1.3.3 AC cables	
1.3.4 Front panel outputs option	
CHAPTER 2. Specifications	pg. 7
2.1 200W/400W Series	
800W Series.....	pg. 9
2.2 Supplemental characteristics	pg. 11
CHAPTER 3. Installation	pg. 12
3.1 General	
3.2 Initial inspection	
3.2.1 Mechanical inspection	
3.2.2 Preparation for use	
3.3 AC source requirements	
3.4 Cooling and placement	
3.5 Rack mounting	
3.6 Power connection	
3.7 Connecting the load	pg.13
3.7.1 Selecting wire size	
3.7.2 Wire termination	pg.14
3.7.3 Single load connection, local sense	
3.7.4 Single load connection, remote sensing	pg.15
3.7.5 Multiple load connections, radial distribution method	
3.7.6 Multiple load connections with distribution terminals	pg.16
3.7.7 Grounding outputs	
3.8 External control connector	
3.8.1 General	
3.8.2 Pin description	pg.17
3.8.3 Technical description	
3.8.4 Default connections.....	pg.18
3.9 Repackaging for shipment	

TABLE OF CONTENTS: ZUP SERIES

3.10	Outline drawings: ZUP 200W & 400W series.....	pg.19
3.11	Outline drawing: ZUP 800W series.....	pg.20
3.12	Outline drawing: front panel connector option	pg.21
CHAPTER 4. Operating Instructions.....		pg.22
4.1	Introduction	
4.2	Controls and Indicators	
4.2.1	Front Panel	
	Table 4-1: Front panel controls and indicators	pg.23
4.2.2	Rear panel	pg.24
4.2.3	Rear panel connections description	pg.25
4.3	Turn-on Checkout Procedure	
4.3.1	General	
4.3.2	Prior to operation	
4.3.3	Constant Voltage check	
4.3.4	Constant Current check	pg.26
4.3.5	OVP check	
4.3.6	UVP check	
4.3.7	Foldback check	
4.3.8	Output On/Off	
4.3.9	Address setting	
4.3.10	Local/Remote Operation	
4.4	Local Operation	pg.27
4.4.1	Introduction	
4.4.2	Constant Voltage Operation	
4.4.3	Constant Current Operation	
4.4.4	Automatic Crossover	pg.28
4.4.5	Over Voltage protection (OVP)	
4.4.6	Under Voltage Protection (UVP)	
4.4.7	Foldback Protection	pg.29
4.4.8	Output On/Off Control	
4.4.9	Last Setting memory	pg.30
4.4.10	Output Voltage & Current programming by external resistor	
4.4.11	Output Voltage Programming by external voltage	pg.32
4.4.12	Output Current programming by external voltage	
4.4.13	Auto Parallel operation.....	pg.33
4.4.14	Series Operation	pg.35
4.4.15	Output good signal.....	pg.37
CHAPTER 5. RS232 & RS485 remote control.....		pg.38
5.1	Introduction	
5.2	Configuration	
5.2.1	Address setting	
5.2.2	RS232 or RS485 selection	
5.2.3	Baud rate setting	
5.2.4	Local/remote selection	

TABLE OF CONTENTS: ZUP SERIES

5.3 Remote programming via RS232.....	pg.39
5.3.1 Introduction	
5.3.2 Rear panel connectors pinout	
5.3.3 RS232 cable	pg.40
5.3.4 Linking power supplies	
5.4 Remote programming via RS485	pg.41
5.4.1 Introduction	
5.4.2 RS485 cable	
5.4.3 Linking power supplies	
5.5 ZUP series command set description	
5.5.1 ID control commands.....	pg.42
5.5.2 Initialization control	
5.5.3 Output control.....	pg.43
5.5.4 Status control	pg.45
5.5.4.1 Registers structure	
5.5.4.2 Status control commands	pg.46
5.6 Communication Protocol.....	pg.47
5.6.1 General information	
5.6.2 Accessing a ZUP unit	
5.6.3 End of message	
5.7. Service Request.....	pg.48
5.7.1 Service Request (SRQ)	
5.7.2 Service Request message	
5.7.3 Service Request enable/disable commands	
CHAPTER 6. Maintenance	pg.49
6.1 Introduction	
6.2 Units under warranty	
6.3 Periodic Maintenance	
6.4 Adjustment and calibration	
6.5 Part replacement and repairs	
6.6 Fuse ratings	
USER'S MANUAL INDEX	pg.50

WARRANTY

This Nemic-Lambda product is warranted against defects in materials and workmanship for a period of three years from date of shipment .During the warranty period, Nemic-Lambda will, at it's option, either repair or replace products which prove to be defective.

LIMITATION OF WARRANTY

The warranty shall not apply to defects resulting from improper or inadequate usage or maintenance by the buyer , buyer supplied products or interfacing. The warranty shall not apply to defects resulting from unauthorized modifications or from operation exceeding the environmental specifications of the product.

Nemic-Lambda does not warrant the buyers circuitry or malfunctions of Nemic-Lambda products resulting from the buyer's circuitry. Furthermore, Nemic-Lambda does not warrant any damage occurring as a result of the buyer's circuitry or the buyer's - supplied products.

No other warranty is expressed or implied.

WARRANTY SERVICE

This product must be returned to an authorized Nemic-Lambda service facility for repairs or other warranty service. For products returned to Nemic-Lambda for warranty service, the buyer shall prepay shipping charges to Nemic-Lambda and Nemic-Lambda shall pay the shipping charges to return the product to the buyer.

DISCLAIMER

The information contained in this document is subject to change without notice. Nemic-Lambda shall not be liable for errors contained in this document or for incidental or consequential damages in connection with the furnishing, performance or use of this material. No part of this document may be photocopied, reproduced or translated into another language without the prior written consent of Nemic-Lambda.

TRADEMARK INFORMATION

Microsoft[™] and Windows[™] are trademarks of Microsoft Corporation.

SAFETY INSTRUCTIONS

CAUTION

The following safety precaution must be observed during all phases of operation, service and repair of this equipment. Failure to comply with the safety precautions or warnings in this document violates safety standards of design, manufacture and intended use of this equipment and may impair the built-in protections within.

Nemic-Lambda shall not be liable for user's failure to comply with these requirements.

INSTALLATION CATEGORY

The ZUP Series has been evaluated to INSTALLATION CATEGORY II. Installation Category (over voltage category) II: local level, appliances, portable equipment etc.. With smaller transient over voltages than Installation Category (over voltage category) III.

GROUNDING

This product is a Safety Class 1 instrument. To minimize shock hazard, the instrument chassis must be connected to an electrical ground. The instrument must be connected to the AC power supply mains through a three conductor power cable, with the ground wire firmly connected to an electrical ground (safety ground) at the power outlet.

For instruments designed to be hard - wired to the supply mains, the protective earth terminal must be connected to the safety electrical ground before an other connection is made. Any interruption of the protective ground conductor, or disconnection of the protective earth terminal will cause a potential shock hazard that might cause personal injury.

FUSES

Fuse must be changed by authorized Nemic-Lambda service personnel only. For continued protection against risk of fire, replace only with the same type and rating of fuse. Refer to maintenance instructions in chapter 6 for fuse rating.

INPUT RATINGS

Do not use AC supply which exceeds the input voltage and frequency rating of this instrument. The input voltage and frequency rating of the ZUP Series is; 100-240V~, 50/60Hz. For safety reasons, the mains supply voltage fluctuations should not exceed +/- 10% of nominal voltage.

LIVE CIRCUITS

Operating personnel must not remove the instrument cover. No internal adjustment or component replacement is allowed by non-Nemic-Lambda qualified service personnel. Never replace components with power cable connected. To avoid injuries, always disconnect power, discharge circuits and remove external voltage sources before touching components.

PART SUBSTITUTIONS & MODIFICATIONS

Part substitutions and modifications are allowed by authorized Nemic-Lambda service personnel only. For repairs or modifications, the instrument must be returned to a Nemic-Lambda service facility.

ENVIRONMENTAL CONDITIONS

The ZUP series safety approval applies to the following operating conditions:

- * Indoor use
- * Ambient temperature: 0°C to 50°C
- * Maximum relative humidity: 90% (no dew drop)
- * Altitude: up to 3,000 m
- * Pollution degree 2

SAFETY INSTRUCTIONS

SAFETY SYMBOLS



Instruction manual symbol. The instrument will be marked with this symbol when it is necessary for the user to refer to the instruction manual.



Indicates hazardous voltage.



Indicates ground terminal.

WARNING

The **WARNING** sign denotes a hazard. An attention to a procedure is called. Not following procedure correctly could result in personal injury.

A **WARNING** sign should not be skipped and all indicated conditions must be fully understood and met.

CAUTION

The **CAUTION** sign denotes a hazard. An attention to a procedure is called. Not following procedure correctly could result in damage to the equipment.

Do not proceed beyond a **CAUTION** sign until all indicated conditions are fully understood and met.

FCC COMPLIANCE NOTICE:

Note: This equipment has been tested and found to comply with the limits for a Class A digital device, pursuant to part 15 of the FCC Rules. These limits are designed to provide reasonable protection against harmful interference when the equipment is operated in a commercial environment. This equipment generates uses, and can radiate radio frequency energy and, if not installed and used in accordance with the instruction manual, may cause harmful interference to radio communications. Operation of this equipment in a residential area is likely to cause harmful interference in which case the user will be required to correct the interference at his own expense.

SAFETY INSTRUCTIONS

OUTPUT TERMINALS COVER

WARNING

Hazardous voltages may exist at the output terminals of the 60V models.

Attach the terminals cover, supplied with the unit, to the chassis after connecting the load wires as described below.

After connection of the load wires (refer to par. 3-7), attach the plastic cover to the rear panel of the power supply, using two self tapping screws supplied with the unit. Refer to Fig. 1-1 for details.

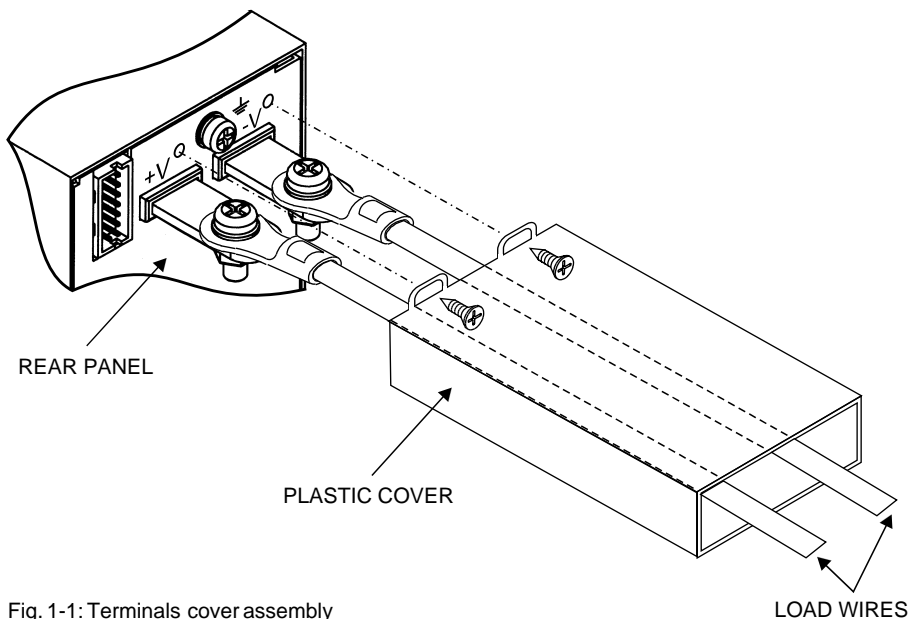

Fig. 1-1: Terminals cover assembly

CHAPTER 1 GENERAL INFORMATION

1.1 USER'S MANUAL CONTENT

This user's manual contains the operating instructions, installation instructions and specifications of the ZUP series. For information related to operation with GPIB control, refer to Nemic-Lambda GP485 user's manual.

1.2 INTRODUCTION

1.2.1 General description

The ZUP series are wide range output switching power supplies with laboratory performance. The ZUP series is power factor corrected and operates from worldwide AC voltage range continuously. Output voltage and current are continuously displayed and LED indicators show the complete operating status of the power supply. The front panel controls allow the user to set the output parameters, the protection levels (over-voltage / under-voltage) and arm the foldback protection to disable the output if the unit switches from Constant-voltage mode to Constant-current mode.

1.2.2 Configurations

The ZUP can be configured into a programmable power system of up to 31 DC outputs using the built-in RS232 or RS485 communication port in the power supply. In a GPIB system the GP485 controller can control up to 31 ZUP units in a single GPIB address.

1.2.3 Control via the serial communication port

The following parameters can be programmed via the serial communication port:

- | | |
|---|--|
| 1. Output voltage setting | 8. Output current measurement |
| 2. Output current setting | 9. Power supply start-up mode
(last setting or safe mode) |
| 3. Output On/Off | 10. Over-voltage protection setting read |
| 4. Arming or release of the foldback protection | 11. Under-voltage limit read |
| 5. Over-voltage protection setting | 12. Remote/Local Control |
| 6. 'Soft' under-voltage limit | |
| 7. Output voltage measurement | |

1.2.4 Output connections

Output connections are made to rear panel bus-bars. Either the positive or negative terminal may be grounded or the output may be floated. The maximum potential (including the output voltage) that either output terminal is from ground must not exceed 60V. Local or remote sense may be used. In remote sense, the maximum voltage drop on each wire is 0.5V.

1.2.5 Analog voltage programming

Analog inputs are provided at the rear panel for analog voltage programming of output voltage and current, and On/Off control. Inputs are provided for resistive programming of the output voltage and current.

1.2.6 Parallel operation

ZUP units of the same output voltage and current rating can be paralleled in master-slave configuration with automatic current sharing for power-up purposes.

1.2.7 Cooling and mechanical construction

The Zup series is fan cooled. Upon installation take care to allow free air flow into the power supply via the front panel and out of the power supply via the rear panel. The ZUP series is contained in a compact, lightweight package which allows for easy installation and space saving in the application

1.3 ACCESSORIES

1.3.1 General

Accessories are delivered with the power supply or separately upon ordering. Below are listed possible accessories and ordering numbers.

PARTNo.	DESCRIPTION
NL 100	19" rack, 3U height
NL 101	Blank panel for 19" rack
NL 102	Additional instruction manual

1.3.2 Serial link cables

Serial link cable, for linking power supplies by RS485 communication is provided with the power supply according to order. Cable description: 0.5m typ. length, shielded, EIA-568A type plugs, 8 contacts. Refer to par.5.3.4, for details.

1.3.3 AC Cables

PART No.	MARKET	DESCRIPTION
----------	--------	-------------

NC301	USA and Japan	15A, 125V, unshielded, 2m typ. length, with IEC320 connector on one side and NEMA-5-15P connector the on other side.
NC302	Europe	10A, 250V, unshielded, 2m typ. length, with IEC320 connector on one side and INT'L 7 standard VII, dual earthing on the other side.
NC303	General	10A, 250V, unshielded, 2m typ. length, with IEC320 connector on one side and unterminated stripped wires on the other side. Use the cable only with plug approved by the national safety standards of the country of usage.

1.3.4 Front Panel Outputs option

In cases where load connection at the front panel is required, optional Front Panel output Jacks for a load current of 20A maximum is available. Please note that the power supply height is increased with this option. Refer to outline drawing (par. 3.12) for details.

ORDER No.	DESCRIPTION
ZUP <input type="checkbox"/> /L	20A Front Panel Output Jacks

CHAPTER 2 SPECIFICATIONS

2.1 SPECIFICATIONS: 200W/400W Series

MODEL	ZUP6-33	ZUP6-66	ZUP10-20	ZUP10-40	ZUP20-10	ZUP20-20	ZUP36-6	ZUP36-12	ZUP60-3.5	ZUP60-7		
OUTPUT VOLTAGE (*1)	V	0 ~ 6	0 ~ 10	0 ~ 10	0 ~ 20	0 ~ 20	0 ~ 36	0 ~ 36	0 ~ 60	0 ~ 60		
OUTPUT CURRENT (*2)	A	0 ~ 33	0 ~ 66	0 ~ 20	0 ~ 40	0 ~ 10	0 ~ 6	0 ~ 12	0 ~ 3.5	0 ~ 7		
RATED OUTPUT POWER	W	198	396	200	400	200	400	216	432	210		
CONSTANT LOAD REGULATION VOLTAGE	-	0.005% +2mV from no load to full load, constant input voltage										
LINE REGULATION	-	0.005% +1mV from 85-132VAC or 170-265VAC, constant load										
RMS RIPPLE (6Hz-1MHz Bandwidth)	mV	5										
RIPPLE (pk-to-pk, 20MHz Bandwidth)	mV	50										
RECOVERY TIME (*4)	ms	1	0.5	0.2	0.2	0.2	0.2	0.2	0.2	0.2		
TEMPERATURE COEFFICIENT	-	30ppm/°C from rated voltage following 30-minute warm-up										
TEMPERATURE DRIFT	-	0.01% +2mV change in output over 8-hour interval under constant line, load and ambient temperature following 30-minute warm-up										
UP PROGRAMMING RESPONSE TIME	ms	50ms (From zero volts to full scale, resistive load, current setting at max.)										
DOWN PROGRAMMING RESPONSE TIME	ms	50										
FULL LOAD NO LOAD	ms	250	350	400	400	500	500	750	750	750		
LOAD REGULATION	-	0.01% +5mA for load voltage change equal to unit voltage rating, constant input voltage.										
LINE REGULATION	-	0.01% +2mA from 85-132VAC or 170-265VAC, constant load										
RMS RIPPLE (5Hz-1MHz Bandwidth)	mA	50	100	25	50	15	30	7.5	15	5		
TEMPERATURE COEFFICIENT	-	100ppm/°C from rated current following 30 minute warm-up										
TEMPERATURE DRIFT	-	0.02% +5mA change in output over 8-hour interval under constant line, load and ambient temperature following 30 minute warm-up										
PROGRAMMING (*3)	VOLTAGE	-	Better than 0.028% of rated output voltage									
	ACCURACY	-	0.02% +5mV 0.02% +8mV 0.02% +12mV 0.02% +26mV 0.02% +35mV									
	CURRENT	-	Better than 0.03% of rated output current									
OVERVOLTAGE PROTECTION (*5)	ACCURACY	-	0.4% +40mA									
	V	0 ~ 7.5	0 ~ 13	0 ~ 24	0 ~ 24	0 ~ 40	0 ~ 40	0 ~ 66	0 ~ 66	0 ~ 66		
HOLD UP TIME	-	20ms at 100V/200VAC, rated output voltage and output current										
DISPLAY	VOLTAGE	-	3 digits (6V, 20V, 36V, 60V) 3.5 digits (10V) accuracy: 0.2% +/- 2 digits									
	CURRENT	-	3 digits accuracy: 0.5% +/- 3 digits									
OUTPUT PROTECTIONS	STATUS	-	CV/CC, Alarm, Fold, Local/Remote, ON/OFF									
	OVER VOLTAGE, Over Temperature, Foldback	-	Over Voltage, Over Temperature, Foldback									
INPUT	INPUT VOLTAGE (*8)	-	85 ~ 265VAC Continuous, 47 ~ 63Hz									
	INPUT CURRENT (*6)	A	3.0/1.5	5.6/2.7	2.9/1.4	5.6/2.7	2.9/1.4	5.6/2.7	2.9/1.4	5.6/2.7	2.9/1.4	
	INPUT CURRENT HARMONICS	-	Complies with EN61000-3-2, Class A									
	POWER FACTOR (TYP)	-	0.99 at 100/200VAC, 100% Load									
EFFICIENCY (*6)	%	69/72	74/77	73/77	79/82	74/78	79/83	76/80	80/84	75/79	80/84	
	INRUSH CURRENT (*7) 100/200V	A	15/30	15	15/30	15	15/30	15	15/30	15	15/30	

2.1 SPECIFICATIONS: 200W/400W Series continued

	ZUP6-33	ZUP6-66	ZUP10-20	ZUP10-40	ZUP20-10	ZUP20-20	ZUP36-6	ZUP36-12	ZUP60-3.5	ZUP60-7	
ENVIRON- MENT	<ul style="list-style-type: none"> OPERATING TEMPERATURE - 0 ~ 50 °C; 100% Load. OPERATING HUMIDITY - 30 ~ 90% RH (No Dewdrop) STORAGE TEMPERATURE - -20 ~ 70 °C STORAGE HUMIDITY - 10 ~ 95% RH (No Dewdrop) VIBRATION (*9) - 10 ~ 55Hz, Amplitude (sweep 1min) Less than 2G, X, Y, Z, 1 hour each. SHOCK - Less than 20G WEIGHT - Kg 2.9 3.2 2.9 3.2 2.9 3.2 2.9 3.2 2.9 3.2 SIZE (WxHxD) - mm 70 x 124 x 350. 										
MECHANI- CAL	<ul style="list-style-type: none"> EXTERNAL OUTPUT ON/OFF - By TTL Signal or Dry Contact - refer to instruction manual EXTERNAL OUTPUT GOOD - Open collector - refer to instruction manual EXTERNAL OUTPUT VOLTAGE PROGR. - By Voltage (0 ~ 4V) or by Resistance (0 ~ 4K) refer to instruction manual EXTERNAL OUTPUT CURRENT PROGR. - By Voltage (0 ~ 4V) or by Resistance (0 ~ 4K) refer to instruction manual REMOTE SENSING - Possible, maximum 0.5V drop on each load wire COMMUNICATION INTERFACE - RS232 and RS485 Built-in, IEEE488 Optional 										
APPROVALS	<ul style="list-style-type: none"> SAFETY STANDARDS - UL 3111-1, EN61010-1 EMC STANDARDS - EN 61326-1, IEC 61326 -1, FCC part 15 (class A) 										
CONDUCTED EMI	<ul style="list-style-type: none"> RADIATED EMI - EN55022-B, FCC-B, VCCI-2 EN55022-A, FCC-A, VCCI-1 										
SERIAL OPERATION	<ul style="list-style-type: none"> Up to 2 units, refer to instruction manual 										
PARALLEL OPERATION	<ul style="list-style-type: none"> Master - slave method: up to 5 units, refer to instruction manual 										
COOLING	<ul style="list-style-type: none"> Forced air by blower fan, (blower fan is mounted within unit) 										
WITHSTAND VOLTAGE	<ul style="list-style-type: none"> Input-Chassis: 2.0kVAC 1 min. Input-Output: 3.0kVAC 1 min. Output-Chassis: 500VAC 1min. 										
ISOLATION RESISTANCE	<ul style="list-style-type: none"> More than 100MΩhm at 25°C and 70% R.H. 										

NOTES:

- * 1 MINIMUM VOLTAGE IS GUARANTEED TO MAXIMUM 0.2% OF THE RATED OUTPUT VOLTAGE.
- * 2 MINIMUM CURRENT IS GUARANTEED TO MAXIMUM 0.4% OF THE RATED OUTPUT CURRENT.
- * 3 GIVEN FOR CONTROL OF THE OUTPUT VIA THE SERIAL COMMUNICATION OR VIA FRONT PANEL CONTROLS.
- * 4 TIME FOR RECOVERY TO WITHIN +/-50mV AGAINST CURRENT CHANGE OF 50% TO 100%.
- * 5 INVERTER SHUT DOWN METHOD, MANUAL RESET BY AC INPUT RECYCLING.(OVP WILL SHUT DOWN OUTPUT).
- * 6 AT 100V/200V AND MAXIMUM OUTPUT POWER.
- * 7 FOR 200W UNITS - AT COLD START Ta = 25°C.
- * 8 FOR CASES WHERE CONFORMANCE TO VARIOUS SAFETY SPECS, (UL, IEC ETC.) ARE REQUIRED TO BE DESCRIBED AS 100-240VAC (50/60Hz) ON NAME PLATE.
- * 9 WHEN MOUNTED WITH MOUNTING SCREWS.

2.1 SPECIFICATIONS: 800W Series

MODEL	ZUP6-132	ZUP10-80	ZUP20-40	ZUP36-24	ZUP60-14	
OUTPUT VOLTAGE (*1)	V 0 ~ 6	0 ~ 10	0 ~ 20	0 ~ 36	0 ~ 60	
OUTPUT CURRENT (*2)	A 0 ~ 132	0 ~ 80	0 ~ 40	0 ~ 24	0 ~ 14	
RATED OUTPUT POWER	W 792	800	800	864	840	
CONSTANT VOLTAGE	- 0.005% +2mV from no load to full load, constant input voltage					
LINE REGULATION	- 0.005% +1mV from 85-132VAC or 170-265VAC, constant load					
RMS RIPPLE (5Hz-1MHz Bandwidth)	mV 8	8	5	5	5	
RIPPLE (pk to pk, 20MHz Bandwidth)	mV 100	90	80	70	60	
RECOVERY TIME (*4)	mS 1	0.5	0.2	0.2	0.2	
TEMPERATURE COEFFICIENT	- 30ppm/ °C from rated voltage following 30-minute warm-up					
TEMPERATURE DRIFT	- 0.01% +2mV change in output over 8-hour interval under constant line, load and ambient temperature following 30-minute warm-up					
UP PROGRAMMING RESPONSE TIME	mS 60mS	(From zero volts to full scale, resistive load, current setting at max.)				
DOWN PROGRAMMING RESPONSE TIME	mS 50					
FULL LOAD	mS 250	350	400	500	750	
NO LOAD	mS					
LOAD REGULATION	- 0.07% + 10mA for load voltage change equal to unit voltage rating, constant input voltage.					
LINE REGULATION	- 0.01% +5mA from 85-132VAC or 170-265VAC, constant load					
RMS RIPPLE (5Hz-1MHz Bandwidth)	mA 200	100	60	30	20	
TEMPERATURE COEFFICIENT	- 100ppm/°C from rated current following 30 minute warm-up					
TEMPERATURE DRIFT	- 0.05% + 10mA change in output over 8-hour interval under constant line, load and ambient temperature following 30 minute warm-up					
PROGRAMMING (*3)	VOLTAGE	RESOLUTION	Better than 0.028% of rated output voltage			
		ACCURACY	- 0.02% + 5mV	- 0.02% + 8mV	- 0.02% + 12mV	- 0.02% + 26mV
	CURRENT	RESOLUTION	Better than 0.03% of rated output current			
		ACCURACY	- 0.4% + 40mA			
OVERVOLTAGE PROTECTION (*5)	V 0-7.5	0-13	0-24	0-40	0-66	
HOLD UP TIME	- 20mS at 100V/200VAC, rated output voltage and output current					
DISPLAY	VOLTAGE	- 3 digits (6V, 20V, 36V, 60V) 3.5 digits (10V) accuracy: 0.2% +/- 2 digits				
	CURRENT	- 3.5 digits (132A), all others 3 digits accuracy: 0.5% +/- 3 digits				
	STATUS	- CV/CC, Alarm, Fold, Local/Remote, ON/OFF				
OUTPUT PROTECTIONS	- Over Voltage, Over Temperature, Foldback					
INPUT VOLTAGE (*7)	- 85 ~ 265VAC Continuous, 47 ~ 63Hz					
INPUT CURRENT (*6)	A 11.2 / 5.4	11.2 / 5.4	11.2 / 5.4	11.2 / 5.4	11.2 / 5.4	
INPUT CURRENT HARMONICS	- Complies with ENG1000-3-2, Class A					
POWER FACTOR (TYP)	- 0.99 at 100/200VAC, 100% Load					
EFFICIENCY (*6)	% 74 / 77	77 / 81	79 / 82	80 / 84	80 / 84	
INRUSH CURRENT 100/200V	A 30					

2.1 SPECIFICATIONS: 800W Series continued

	ZUP6-132	ZUP10-80	ZUP20-40	ZUP36-24	ZUP60-14
ENVIRONMENT	OPERATING TEMPERATURE	- 0 ~ 50 °C; 100% Load.			
	OPERATING HUMIDITY	- 30 ~ 90% RH (No Dewdrop)			
	STORAGE TEMPERATURE	-20 ~ 70 °C			
	STORAGE HUMIDITY	- 10 ~ 95% RH (No Dewdrop)			
MECHANICAL	VIBRATION (*8)	- 10 ~ 55Hz, Amplitude (sweep 1min.) Less than 2G, X, Y, Z, 1hour each.			
	SHOCK	- Less than 20G			
	WEIGHT	Kg	5.8		
EXTERNAL FUNCTIONS	SIZE (WxHxD)	mm	140 x 124 x 350 refer to outline drawing		
	OUTPUT ON/OFF	-	By TTL Signal or Dry Contact - refer to instruction manual		
	OUTPUT GOOD	-	Open collector - refer to instruction manual		
	OUTPUT VOLTAGE PROGR.	-	By Voltage (0 ~ 4V) or by Resistance (0 ~ 4K) refer to instruction manual		
	OUTPUT CURRENT PROGR.	-	By Voltage (0 ~ 4V) or by Resistance (0 ~ 4K) refer to instruction manual		
	REMOTE SENSING	-	Possible, maximum 0.5V drop on each load wire		
	COMMUNICATION INTERFACE	-	RS232 and RS485 Built-in, IEEE488 Optional		
APPLICABLE SAFETY STANDARDS	-	UL 3111-1, EN61010-1			
APPLICABLE EMC STANDARDS	-	EN 61326-1, IEC 61326 -1, FCC part 15 (class A)			
CONDUCTED EMI	-	EN55022-B, FCC-B, VCCI-2			
RADIATED EMI	-	EN55022-A, FCC-A, VCCI-1			
SERIAL OPERATION	-	Up to 2 units, refer to instruction manual			
PARALLEL OPERATION	-	Master - slave method: up to 5 units, refer to instruction manual			
COOLING	-	Forced air by blower fan, (blower fan is mounted within unit)			
WITHSTAND VOLTAGE	-	Input - Chassis: 2.0kVAC 1 min. Input - Output: 3.0kVAC 1 min. Output - Chassis: 500VAC 1 min.			
ISOLATION RESISTANCE	-	More than 100MΩhm at 25 °C and 70% R.H.			

NOTES:

- * 1 MINIMUM VOLTAGE IS GUARANTEED TO MAXIMUM 0.2% OF THE RATED OUTPUT VOLTAGE.
- * 2 MINIMUM CURRENT IS GUARANTEED TO MAXIMUM 0.4% OF THE RATED OUTPUT CURRENT.
- * 3 GIVEN FOR CONTROL OF THE OUTPUT VIA THE SERIAL COMMUNICATION OR VIA FRONT PANEL CONTROLS.
- * 4 TIME FOR RECOVERY TO WITHIN +/- 50mV AGAINST CURRENT CHANGE OF 50% TO 100%.
- * 5 INVERTER SHUT DOWN METHOD, MANUAL RESET BY AC INPUT RECYCLING. (OVP WILL SHUT DOWN OUTPUT).
- * 6 AT 100V/200V AND MAXIMUM OUTPUT POWER.
- * 7 FOR CASES WHERE CONFORMANCE TO VARIOUS SAFETY SPECS. (UL, IEC ETC.) ARE REQUIRED TO BE DESCRIBED AS 100-240VAC (50/60Hz) ON NAME PLATE.
- * 8 WHEN MOUNTED WITH MOUNTING SCREWS.

2.2 SUPPLEMENTAL CHARACTERISTICS

The supplemental characteristics give typical but non-warranted performance characteristics. The supplemental characteristics are useful in accessing applications for the power supply. Several kinds of supplemental characteristics are listed below.

1. EVALUATION DATA: Typical performance of the power supply.
2. RELIABILITY DATA: Reliability performance of the power supply.
3. IEC 1000 DATA: Performance of the power supply under IEC 1000 test conditions.
4. EMI DATA: Typical EMI (conducted and radiated) performance of the power supply.

The supplemental characteristics data are held in each Nemic-Lambda sales and service facility. For further details please contact the Nemic-Lambda office nearest you.

CHAPTER 3 INSTALLATION

3.1 GENERAL

This chapter contains instructions for initial inspection, preparation for use and repackaging for shipment. Connection to PC, linking ZUP units and setting the address are described in chapter 5.

NOTE

ZUP series power supplies generate a magnetic field which might affect the operation of other instruments. If your equipment is susceptible to magnetic fields, do not position adjacent to the ZUP.

3.2 INITIAL INSPECTION

Prior to shipment this power supply was inspected and found free of mechanical or electrical defects. Upon unpacking of the power supply, inspect for any damage which may have occurred in transit. Keep all packing materials until inspection has been completed. If any damage is detected, file a claim with the carrier immediately and notify the Nemic-Lambda sales or service facility nearest you.

3.2.1 Mechanical inspection

The mechanical inspection should confirm that there is no exterior damage to the power supply such as broken knobs or connectors and that the front panel and meter face are not scratched or cracked.

3.2.2 Preparation for use

In order to be operational the power supply must be connected to an appropriate AC source. The line voltage must be within the power supply specification. DO NOT apply power before reading paragraph 3.3.

3.3 AC SOURCE REQUIREMENTS

The ZUP series can be operated from a nominal 100V to 240V, single phase, 47 ~ 63Hz. The input voltage range and current required for each model is specified in chapter 2. Make sure that under heavy load, the AC voltage supplied to the power supply does not fall below "low limit" specifications.

3.4 COOLING & PLACEMENT

This power supply is fan cooled. Upon installation ensure sufficient space for air intake (front panel) and exhaust (rear panel). The power supply should be used in an area where the ambient temperature does not exceed +50°C

3.5 RACK MOUNTING

ZUP models can be mounted in a standard 19" rack (3U height). The 200W and 400W models occupy 1/6 rack length. The 800W model occupies 1/3 rack length. The power supplies should be fixed by M4 screws replacing the rubber feet on the bottom of the power supply. The screws must not protrude more than 6mm into the power supply. Refer to the outline drawing in this chapter for mounting details.

3.6 POWER CONNECTION

CAUTION

Connection of this power supply to an AC power source should be made by an electrician or other qualified personnel.

This power supply is equipped with a three conductor power cable. The third conductor is the ground conductor. When the cable is plugged-in to an appropriate receptacle, the power supply is grounded. Under no circumstances should this power supply be operated without an adequate ground connection. If a two contact receptacle is encountered, it must be replaced by a three contact receptacle, properly grounded. This operation should be done by a qualified electrician. It is recommended to keep the AC input wires separate from the DC output and signal wires to avoid interference.

To meet radiated EMI specification, the EMI suppressor clamp should be attached to the AC cable as close as possible to the AC inlet of the power supply.

WARNING

Some components inside the power supply are at AC voltage even when the On/Off switch is in the "Off" position. To avoid the hazard of electric shock, disconnect line cord and load and wait 2 minutes before removing cover.

3.7 CONNECTING THE LOAD

WARNING

Turn off the AC input power before making or changing any rear panel connection. Make sure that all connections are securely tightened before applying power.

3.7.1 Selecting wire size

Two factors must be considered in selecting wire size.

1. Wires should be at least heavy enough to avoid overheating while carrying the power supply load current at the rated load, or the current that would flow in the event the load wire were shorted, whichever is greater.

2. Wire size should be selected to enable voltage drop per lead to be less than 0.5V at the rated current. It is recommended to minimize voltage drop on the wires to prevent excessive output power consumption from the power supply.

Please refer to Tables 3-1 and 3-2 for maximum wire length to limit voltage drop by American and European measurements respectively.

wire size AWG	Resistivity Ohm/ft	Maximum length in feet - to limit voltage drop to 0.5V or less				
		5A	10A	20A	50A	150A
14	2.526	40	20	10	4	1
12	1.589	63	31	15	6	1.7
10	0.9994	100	50	25	10	3
8	0.6285	160	80	40	16	5
6	0.3953	253	126	63	25	8
4	0.2486	400	200	100	40	13
2	0.1564	640	320	160	64	21
0	0.0983	1016	508	254	102	34

Table 3-1: Maximum wire length for 0.5V drop on lead (in feet)

cross sect. area (mm ²)	Resistivity Ohm/km	Maximum length in meters - to limit voltage drop to 0.5V or less				
		5A	10A	20A	50A	150A
2.5	8.21	12.2	6.1	3.0	1.2	0.4
4	5.09	19.6	9.8	4.9	2.0	0.7
6	3.39	29.5	14.7	7.4	2.9	1.0
10	1.95	51.3	25.6	12.8	5.1	1.7
16	1.24	80.6	40.3	20.2	8.1	2.7
25	0.795	125.8	62.9	31.4	12.6	4.2
35	0.565	177.0	88.5	44.2	17.7	5.9

Table 3-2: Maximum wire length for 0.5V drop on lead (in meters)

For current not shown in tables 3-1 and 3-2 use formula: $\text{Maximum length} = 500 / (\text{current} * \text{resistivity})$
 Where current is expressed in amperes and resistivity in ohms/km or ohms/1000ft.

3.7.2 Wire termination

The wires should be properly terminated with terminals securely attached. DO NOT use non terminated wires for load connection at the power supply.

CAUTION

At local sensing, short between +LS or +S to -V or -S or -LS will cause damage to the power supply. Reversing the sense wires might cause damage to the power supply at local and remote sensing.

3.7.3 Single load connection, Local Sensing

Fig. 3-1 illustrates the connection of a single load to the power supply using local sensing. This connection is made via the “External Control Connector” located on the rear panel of the power supply. Local sensing is suitable for applications where load regulation is not critical.

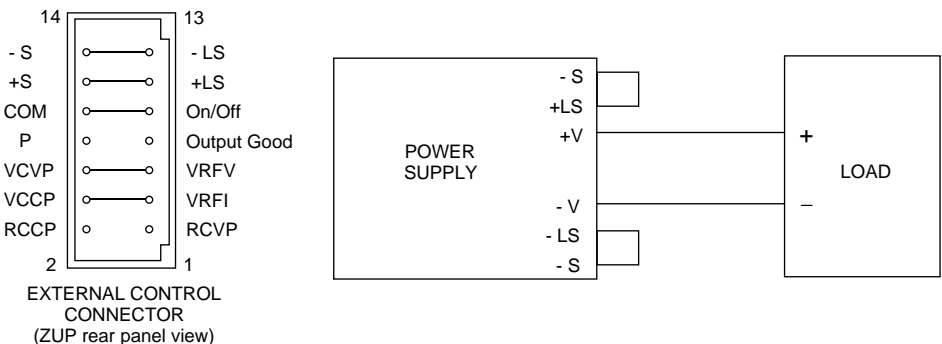

Fig. 3-1: Single load connection, Local Sensing

3.7.4 Single load connection, Remote Sensing

Remote Sensing is used in cases where, in Constant Voltage mode the load regulation is important at the load terminals. Use twisted or shielded wires to minimize noise pick-up. If shielded wires are used, the shield should be connected to the ground at one point, either the power supply chassis or the load ground. The optimal point for the shield ground should be determined by experimentation. At Remote Sensing, the maximum voltage drop allowed at the load wires is 0.5V per wire.

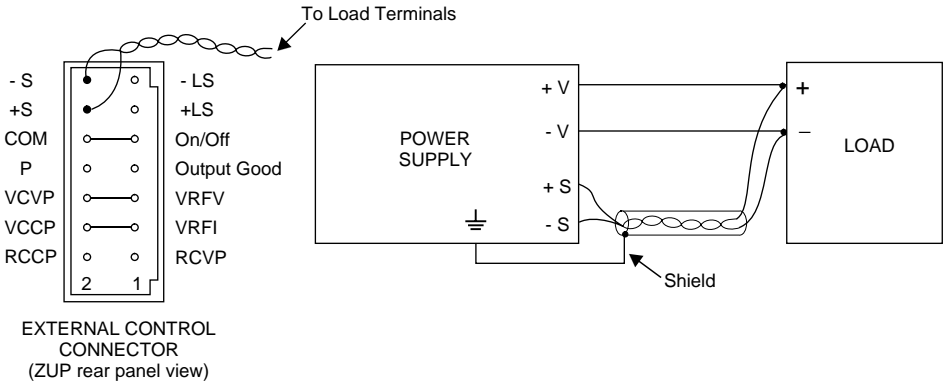

Fig. 3-2: Remote Sensing, single load.

3.7.5 Multiple load connections, radial distribution method

In cases of multiple loads connected to one supply, each load should be connected to the power supply's output terminals using separate pairs of wires. It is recommended that each pair of wires will be as short as possible and twisted or shielded to minimize noise pick-up and radiation. The sense wires should be connected to the power supply output terminals or to the load with the most critical load regulation requirement.

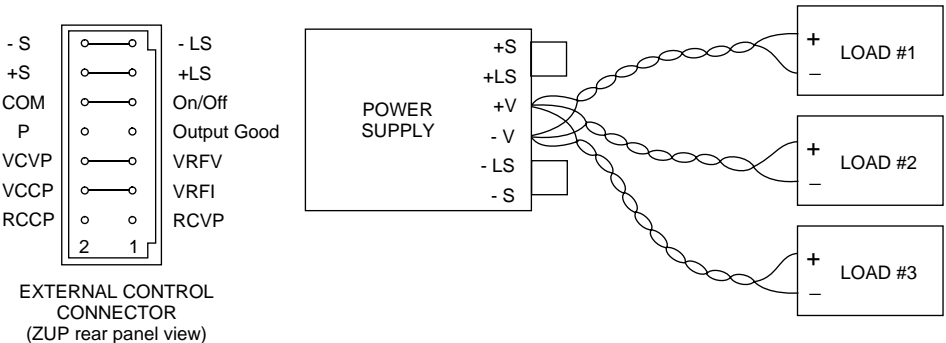

Fig. 3-3: Multiple load connections with distribution terminal

3.7.6 Multiple load connections with distribution terminals

If remotely located output distribution terminals are used, the power supply output terminals should be connected to the distribution terminals by a pair of twisted or shielded wires. Each load should be separately connected to the remote distribution terminals. If Remote Sensing is required, the sensing wires should be connected to the distribution terminals or at the most critical load.

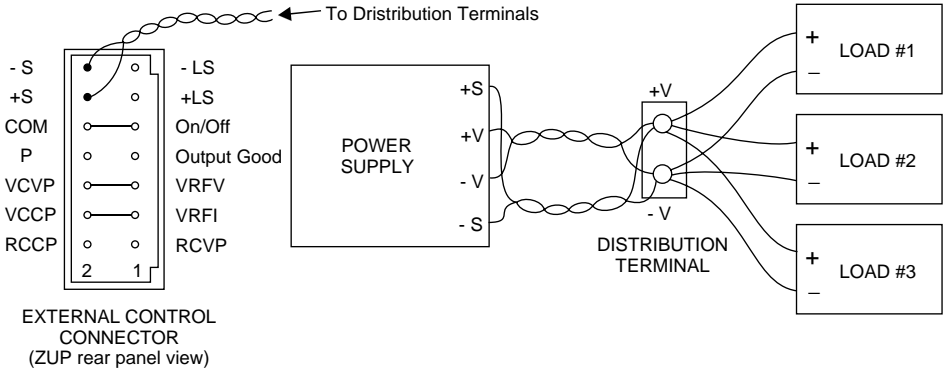

Fig. 3-4: Multiple load connections with distribution terminal

3.7.7 Grounding outputs

Either the positive or negative output terminals can be grounded. To avoid noise problems caused by common-mode current flowing from the load to ground, it is recommended to ground the output terminal as close as possible to the power supply output.

Always use two wires to connect the load to the power supply regardless of how the system is grounded.

WARNING

The maximum potential (including output voltage) that either output terminal is from ground, must not exceed the specified voltage on the front panel.

3.8 EXTERNAL CONTROL CONNECTOR

3.8.1 General

The external control connector, used for analog programming of the power supply, is located on the rear panel of the unit, (Fig. 4-2, item 4). The pin assignment is shown in Fig. 3-5 below.

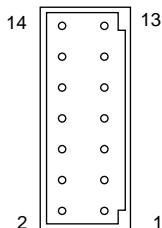

Fig. 3-5: External Control connector pin assignment (ZUP rear panel view)

3.8.2 Pin Description

#	Name	Description	Par.
1	RCVP	Resistive Constant Voltage programming	4.4.10
2	RCCP	Resistive Constant Current programming	4.4.10
3	VRFI	Reference voltage for Constant Current control. (connected to VCCP pin except external voltage or resistive programming).	4.4.10, 11, 12
4	VCCP	Input of the Constant Current control circuit.	4.4.10, 11, 12
5	VRFV	Reference voltage for Constant Voltage control. (connected to VCVP pin except external voltage or resistive programming).	4.4.10, 11, 12
6	VCVP	Input of the Constant Voltage control circuit.	4.4.10, 11, 12
7	OUTPUT GOOD	Open collector output. 0~0.8V during normal operation, open at fault condition (OVP, FOLD and Over-Temp.).	4.4.15
8	P	Parallel connection pin.	4.4.13
9	ON/OFF	On/Off control pin.	4.4.8
10	COM	Common pin for programming, On/off control and Output Good signal. Internally connected to - Sense.	4.4.10, 11, 12 4.4.8
11	+ LS	Positive Local sensing pin.	3.7.3, 4, 5, 6
12	+ S	Positive Sensing pin for remote sense operation.	3.7.3, 4, 5, 6
13	- LS	Negative Local sensing pin.	3.7.3, 4, 5, 6
14	- S	Negative Sensing pin for remote sense operation.	3.7.3, 4, 5, 6

Table3-3: External Control connector pin description

CAUTION

COM pin (10) is connected internally to the - Sense potential. Connection of the COM to another potential or other than shown in this manual may cause damage to the power supply.

3.8.3 External Control Connector - Technical description

1. Connector type : AMP, Part No: 102617-5 14 contacts, double row.
2. Receptacle : AMP, Part No: 87631-9, Polarized, 14 contacts, double row.
3. Receptacle contacts : AMP, Part No: 87523-5 (strip form) or 87523-6 (loose piece).
4. Wires : AWG: 24 to 20.
5. Hand tool for wire connection : AMP, Part No: 90202-2.
6. Applicator for stripper/crimper machine : AMP, Part No: 466905-1

3.8.4 External Control Connector - Default configuration connections

The external control connector is configured for Local sensing and no external On/Off control. Refer to Fig: 3-6 below for the default configuration description. The default configuration is: Local sensing, Rear panel On/Off disabled (On/Off can be controlled by the Front panel or by the serial communication port), and output voltage and current are controlled by the Front panel or by the serial communication port. For other configurations, remove the contact that should be modified, and replace it with a new one with a suitable connection. Replacement contacts are supplied in the packaging of the power supply.

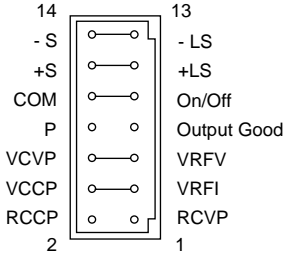

Fig. 3-6:
External Control connector - default configuration
(ZUP rear panel view)

3.9 REPACKAGING FOR SHIPMENT

To ensure safe transportation of the instrument, it is recommended to use the original package. The original packaging material is reusable. If the original package is not available, contact the Nemic-Lambda Sales or service facility near you for details on obtaining suitable packaging and shipping information. Please attach a tag to the power supply describing the problem and specifying the owner, model number and serial number of the power supply.

3.10 OUTLINE DRAWINGS

ZUP 200W and ZUP 400W Series

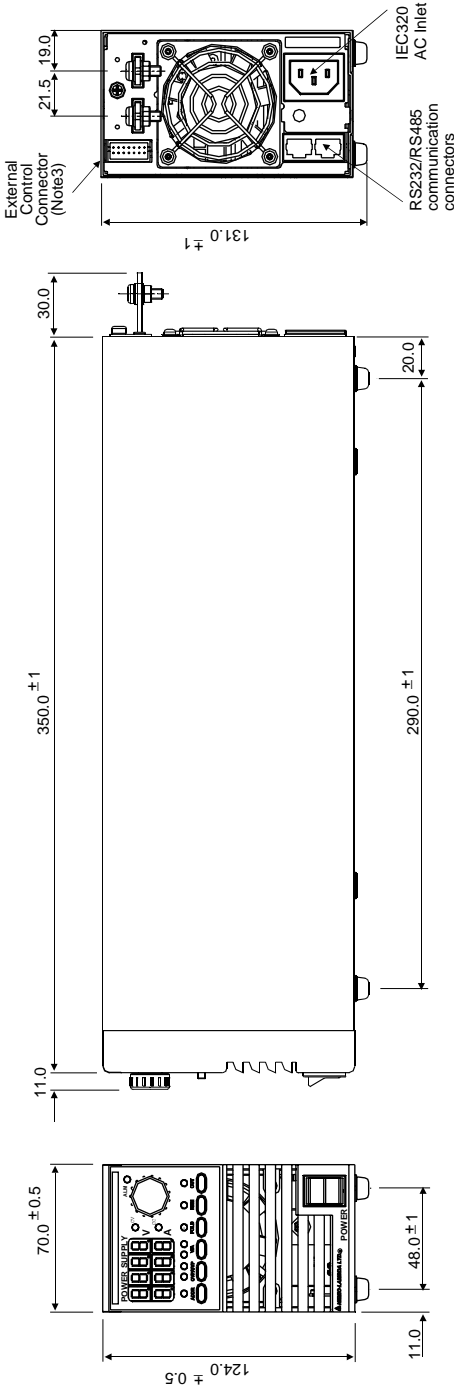

Notes:

1. Mounting screws must not protrude more than 6mm into the power supply.
2. Use M6 or 1/4" screw for lead wires connection, enclosed in the package at time of shipment.
3. Receptacle: AMP, 87631-9, 14 contacts, double row. P/n: 87523-5 or 87523-6.

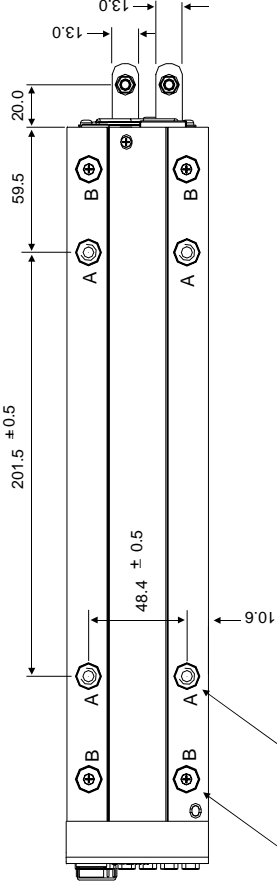

Rubber Bumpers
4 places marked 'B'
(removable)

Mounting Holes
Tap M4 x 4 marked 'A'
(See note 1)

DIMENSIONS: mm
200W /400W units: 70x124x350
200W units: 2.9

WEIGHT: Kg
200W units: 2.9
400W units: 3.2

3.11 OUTLINE DRAWINGS

ZUP 800W Series

DIMENSIONS:

140x124x350 mm.

WEIGHT:

5.8 kg.

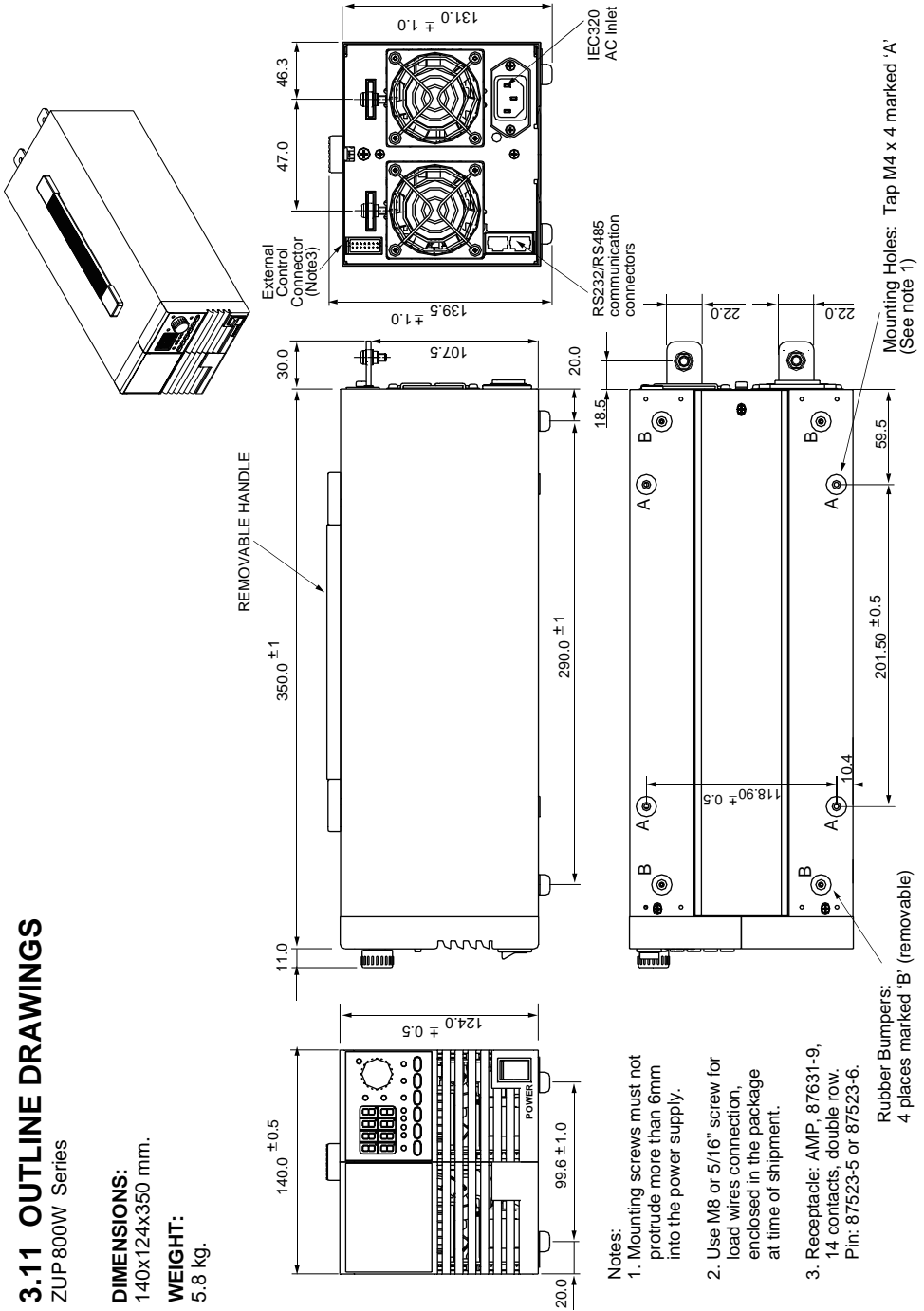

Notes:

1. Mounting screws must not protrude more than 6mm into the power supply.
2. Use M8 or 5/16" screw for load wires connection, enclosed in the package at time of shipment.
3. Receptacle: AMP, 87631-9, 14 contacts, double row. Pin: 87523-5 or 87523-6.

Rubber Bumpers:
4 places marked 'B' (removable)

Mounting Holes: Tap M4 x 4 marked 'A'
(See note 1)

3.12 OUTLINE DRAWINGS

Front Panel Output Jacks Option: available for ZUP200W , ZUP400W and ZUP800W series.

ZUP200/L and ZUP400/ L

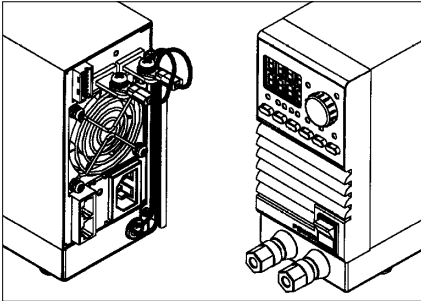

ZUP800/L

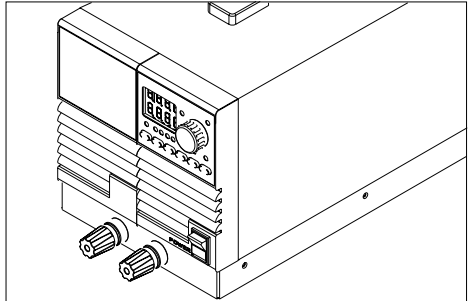

Up to 20A output current via front panel jacks.

CAUTION: ZUP800 front panel output is protected against overcurrent by 25A 125V Fast acting fuse. For continued protection against risk of fire, replace only with same type and rating of fuse.

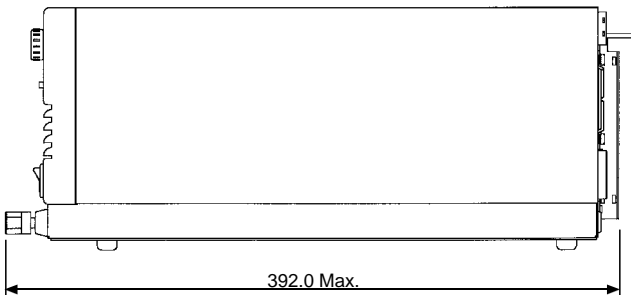
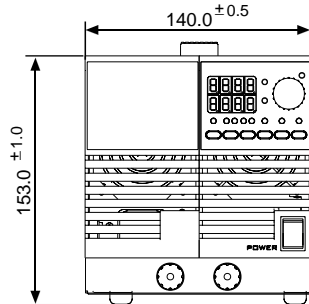
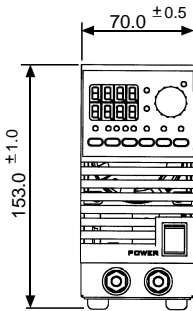

Physical Dimensions in mm.

CHAPTER 4 OPERATING INSTRUCTIONS

4.1 INTRODUCTION

This chapter describes the operating modes, controls and indicators of the ZUP power supply series. Details of local operation via the front panel and various modes of operation are described in this chapter, including remote analog control via the rear panel. For computer control via the Serial port (RS232 or RS485), refer to chapter 5.

4.2 CONTROLS AND INDICATORS

4.2.1 Front panel

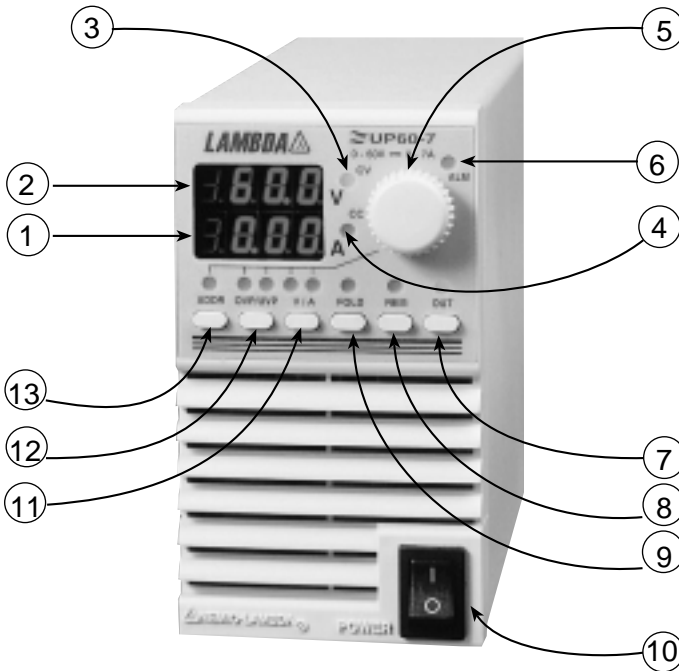

Fig. 4-1: Front panel controls and indicators

Table 4-1: Front panel controls and indicators

#	Control/Indicator	Description	Par.
1	AMPS Display	Actual output current display at normal operation. While adjusting the output current, the set value will be shown. The display will automatically return to show the actual current approx. 3sec from completion of adjustment.	
2	VOLTS Display	Actual output voltage display at normal operation. The measurement circuits monitor the voltage at the sensing points, hence at remote sensing where there is voltage drop on the load wires, the voltage at the power supply output terminals will be higher than the displayed value. Attention should be taken not to exceed the output power rating. While adjusting the output voltage, the set value will be shown. The display will automatically return to show the actual voltage approx. 3sec after completion of adjustment.	
3	CV Indicator	CV LED indicates that the power supply is regulating it's output at a constant voltage.	
4	CC Indicator	CC LED indicates that the power supply is regulating it's output at a constant current.	
5	ADJUST knob (Rotary pulse generator)	The ADJUST knob functions to determine the following output parameters:	
		1. Output voltage adjust - as determined by V/A pushbutton	4.4.2
		2. Output current adjust - as determined by V/A pushbutton	4.4.3
		3. Over voltage protection adjust - as determined by OVP/UV P pushbutton	4.4.5
		4. Under voltage soft limit adjust-as determined by OVP/UV P pushbutton	4.4.6
	5. Address selection	5.2.1	
6	ALM Indicator	ALM indicates alarm caused by activation of one of the following protections: * Over voltage protection * Over temperature protection * Foldback protection	
7	OUT Pushbutton	Main function: Enable or disable the power supply output.	4.4.8
		Auxiliary function: Press and hold OUT pushbutton for approx. 3sec to change function to select between safe mode restart and automatic restart.	4.4.9
8	REM Pushbutton	Main function: Select between local or remote operation. Auxiliary function: Press and hold REM pushbutton for approx. 3sec to change function to select between RS232 or RS485 communication.	5.2.4
9	FOLD Pushbutton	Pressing FOLD pushbutton arms foldback protection which shuts down output if supply transits from CV to CC.	4.4.7

Table 4-1 contd.: Front panel controls and indicators

#	Control/Indicator	Description	Par.
10	AC ON/OFF	Turns AC power On and Off.	
11	V/A Pushbutton	Selects the voltage or current adjust mode. fast or slow adjustment speed can be selected by pressing the pushbutton consecutively. Adjustment is made by rotating the Adjust knob.	4.4.2 4.4.3
12	OVP / UVP	Makes selection between Over-voltage or Under-voltage adjust mode. Adjustment is made by rotating the Adjust knob.	4.4.5 4.4.6
13	ADDR	Main function: Selects the address for remote control. The adjustment is made by rotating the Adjust knob. Auxiliary function: Holding ADDR pressed for approx. 3sec. changes the function to Baud-rate selection.	5.2.1 5.2.3

4.2.2 Rear Panel

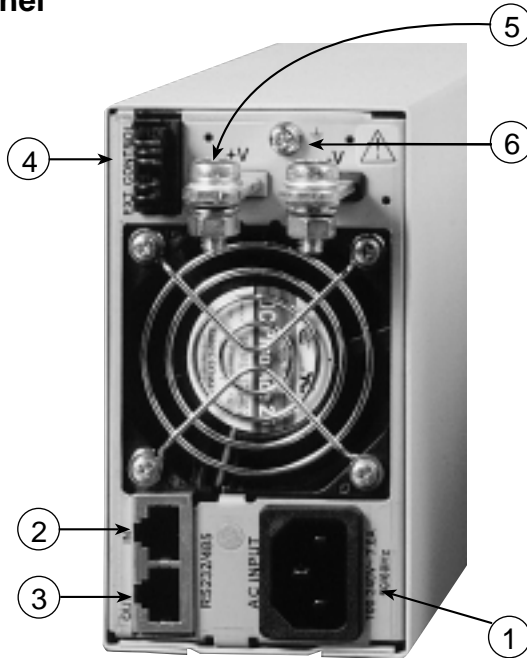

Fig. 4-2: Rear panel connections

4.2.3 Rear Panel Connections description

#	Connection	Description	Par.
1	AC Inlet	IEC type appliance inlet.	3.6
2	Remote In	EIA/TIA-568A type connector, used for connecting power supply to RS232 or RS485 port of computer for remote control purposes. When using several power supply units in a power system, the first unit Remote-in is connected to the computer and the remaining units are chained, Remote-In to Remote-Out.	5.3.4
3	Remote Out	EIA/TIA-568 type connector, used for chaining power supplies to form a serial communication bus.	5.3.4
4	External control	Connector containing control and signal lines for external (remote) control of the power supply. +/- Sense, On/Off, Output voltage and current programming by external resistor and Output voltage and current programming by external voltage and Output Good signal.	3.8
5	Output Bus Bars	Bus bars for output connection. Use M6 or 1/4" screws for load wire connections.	3.7
6	Ground thread	M4 thread for grounding either the positive or negative output.	

4.3 TURN-ON CHECKOUT PROCEDURE

4.3.1 General

The following procedure ensures that the power supply is operational and may be used as a basic incoming inspection check.

4.3.2 Prior to operation

Check that the Rear panel external control receptacle is properly inserted into the connector and the wires are connected as shown in Fig: 3-6. Connect the unit to an AC source as described in paragraph 3.6. Connect a DVM to the output terminals.

4.3.3 Constant Voltage check

Turn-on the power supply. Turn on the output by pressing OUT pushbutton so the OUT LED illuminates. Momentarily press V/A pushbutton, until the V LED illuminates and the VOLTS display shows FA_V. The AMPS display will show the last setting of the output voltage. Rotate the Adjust knob at the front panel and check that the output voltage can be varied throughout the entire range. Check that the AMPS display shows the correct output voltage (within the display specifications). Momentarily press V/A pushbutton again, so the A LED illuminates and the VOLTS display shows FA_A. The AMP display will show the last setting of the output current. Rotate the Adjust knob and check that the AMP display varies. Set the AMP display to the rated output current.

4.3.4 Constant Current check

Turn off the power supply. Connect an electronic load with suitable voltage and current rating to the output terminals, as explained in paragraph 3.7.3. Turn-on the power supply. Vary the load current and check that the unit regulates the output voltage while the load current is smaller than the power supply current rating. Further increase the load current and check that the power supply regulates the output current.

4.3.5 OVP check

Adjust the output voltage to zero using the front panel knob. Momentarily press OVP/UVP pushbutton until the OVP LED illuminates and the VOLTS display shows OUP. The AMPS display will show the last setting of the OVP level. Rotate the Adjust knob to 50% of the supply's voltage rating. Adjust the output voltage toward it's maximum and check that the output voltage cannot be increased more than the OVP setting.

4.3.6 UVP check

Adjust the output voltage to the rated voltage using the front panel knob. Momentarily press OVP/UVP pushbutton until the UVP LED illuminates and the VOLTS display shows UUP. The AMPS display will show the last setting of the UVP level. Rotate the ADJUST knob to 50% of the supply's voltage rating. Adjust the output voltage toward it's minimum and check that the output voltage cannot be decreased below the UVP setting.

4.3.7 Foldback check

Set the load current to 50% of the supply rating. Momentarily press FOLD pushbutton and check that the FOLD LED illuminates. Increase the load current toward the supply current rating. Check that the output voltage and current fall to zero when the load current reaches the Constant Current setting. The FOLD LED should flash, the ALM LED illuminates and the output is disabled in this condition.

Reduce the load current setting below the power supply current rating and momentarily press OUT pushbutton. Check that the output voltage and current recover and FOLD continuously illuminates. Momentarily press the FOLD pushbutton and check that FOLD LED turns off.

4.3.8 Output On/Off

Repeatedly press OUT pushbutton and check that the power supply output is turned On and Off. While the output is On, the OUT LED illuminates. While the output is Off, the LED is Off.

4.3.9 Address setting

Momentarily press ADDR pushbutton so the ADDR LED illuminates and the AMPS display shows Addr. The VOLTS display shows the last address setting. Rotate the ADJUST knob and check that the VOLTS display varies between 0 and 31.

4.3.10 Local/Remote operation

Repeatedly press REM pushbutton and check that REM LED turns on and off. While the power supply is at Remote mode, the LED is on and while at Local mode, the LED is off. While the LED is off, turn off the power supply, remove the DVM and the load wires.

4.4 LOCAL OPERATION

4.4.1 Introduction

This paragraph describes the operating modes not involved in programming the power supply via its serial communication port. Operation utilizing the front and rear panel are described in this paragraph. For information regarding serial port usage, please refer to chapter 5.

The REM LED on the front panel indicates whether the power supply is in Local or Remote mode. The extinguished LED indicates Local operation. If the LED illuminates, the REM pushbutton (fig.4-1, item 8), should be pressed to change the operating mode to Local.

4.4.2 Constant Voltage Operation

1. In constant voltage mode, the power supply maintains the output voltage at the selected value while the load current varies as required by the load.
2. While the power supply is operating at constant voltage, the CV LED on the front panel illuminates.
3. For coarse output voltage adjustment, press V/A consecutively, until the V LED illuminates, and the VOLTS display shows FA_V. The AMPS display will show the output voltage setting value. Rotate the ADJUST knob to set the output voltage. At this mode, approx. 6 turns are required to adjust the entire range. Approx. 3sec after the adjustment, the display returns to show the actual voltage and current.
4. For fine adjustment of output voltage, press V/A consecutively until the V LED illuminates and the VOLTS display shows SL_V. The AMPS display will show the output voltage setting value. Rotate the ADJUST knob to set the output voltage. At this mode the adjustment resolution is maximal. Approx 3sec. after the adjustment, the display returns to show the actual voltage and current.

NOTE

If after completing the adjustment the display shows a different value than the setting, the power supply may be at current limit. Check the load condition and the power supply current limit setting.

NOTE

The maximum and minimum setting values of the output voltage are limited by the over voltage and under voltage protection settings. Refer to par. 4.4.5 and 4.4.6 for details.

4.4.3 Constant Current Operation

1. In constant current mode the power supply maintains the output current at the selected value, while the load voltage varies with the load requirement.
2. While the power supply is operating at constant current, the CC LED on the front panel illuminates.
3. For coarse output current adjustment, press V/A consecutively, until the A LED illuminates, and the VOLTS display shows FA_A. The AMPS display will show the output current setting value. Rotate the ADJUST knob to set the output current. At this mode, approx. 6 turns are required to adjust the entire range. Approx. 3sec after the adjustment, the display returns to show the actual voltage and current.
4. For fine adjustment of output current, press V/A consecutively until the A LED illuminates and the VOLTS display shows SL_A. The AMPS display will show the output current setting value. Rotate the ADJUST knob to set the output current. At this mode the adjustment resolution is maximal. Approx 3sec. after the adjustment, the display returns to show the actual voltage and current.

4.4.4 Automatic Crossover

If the power supply operates in Constant voltage mode while the load current is increased to greater than the current limit setting, the power supply will automatically switch to Constant current mode. If the load is decreased to less than the current limit setting, the power supply will automatically switch back to Constant voltage mode.

4.4.5 Over Voltage Protection (OVP)

1. The OVP circuit monitors the voltage at the power supply sensing points thus guaranteeing the protection level at the load. Upon detection of Over Voltage condition, the power supply will shut down. To resume operation, the power switch should be turned off for approx. 30sec. Prior to turn-on, check carefully that the sense wires are connected correctly and secured.
2. OVP setting values are limited at the minimum and maximum levels. At minimum level, the OVP level is limited by the Output Voltage setting, therefore the OVP level cannot be adjusted below the Output Voltage. At maximum level, the OVP level is limited to the values shown in Table4-1.

MODEL (by output voltage)	6V	10V	20V	36V	60V
Maximum OVP	7.5V	13V	24V	40V	66V

Table4-1: Maximum OVP setting levels.

3. For over voltage protection adjustment, press OVP/UVP consecutively, until the OVP LED illuminates and the VOLTS display shows OUP. The AMPS display will show the over voltage protection setting value. Rotate the ADJUST knob to set the over voltage protection level. Approx. 3sec after the adjustment, the display returns to show the actual voltage and current.
4. In order to see the value of the OVP, press OVP/UVP pushbutton, so that the OVP LED illuminates. At this time the display will show the OVP set value for approx. 3sec.
5. The minimum over voltage level is approx. 105% of the output voltage set value. Attempting to adjust the over voltage protection below this value will result in no response to the adjustment attempt.
6. In case the OVP is triggered, the front panel control is disabled until the AC input is recycled by turning the AC ON/OFF switch to OFF and after approx. 10 sec. to ON.

4.4.6 Under Voltage Protection (UVP)

1. The UVP prevents adjustment of the output voltage below a certain limit. The combination of UVP and OVP functions allows the user to create a protection window for sensitive loads circuitry.
2. For under voltage protection adjustment, press OVP/UVP consecutively until the UVP LED illuminates and the VOLTS display shows UUP. The AMPS display will show the under voltage protection setting value. Rotate the ADJUST knob to set the under voltage protection level.
3. In order to see the set value of the UVP, press OVP/UVP pushbutton, so that the UVP LED illuminates. At this time the display will show the UVP set value for approx. 3sec.
4. The maximum under voltage level is approx. 95% of the output voltage set value. An attempt to adjust the under voltage protection above this value will result in no response to the adjustment attempt.
5. The under voltage protection is a software protection only.

4.4.7 Foldback Protection

1. Foldback protection will shut down the power supply output if the load current exceeds the current limit setting level. This protection is useful when the load circuitry is sensitive to over current condition.
2. To arm the Foldback protection, the FOLD pushbutton should be pressed so the FOLD LED illuminates. At this condition transition from Constant Voltage to Constant Current mode will activate the Foldback protection.
3. Activation of the Foldback protection disables the power supply's output, turns on the ALM (alarm) LED and flashes the FOLD LED.
4. There are 2 modes of releasing an activated Foldback protection.
 1. Short press on FOLD pushbutton enables the output and re-arms the protection circuit. If the load is smaller than the current limit level, the power supply will restore normal operation. If the load is greater than the current limit level, the output will be disabled again and Foldback indicators will be on.
 2. Long press (approx. 3sec) on FOLD pushbutton will disable the Foldback protection circuit and enable the output. The power supply will restore operation to Constant Voltage or Constant Current mode depending on the load characteristics and power supply setting.

4.4.8 Output ON/OFF Control

The ON/OFF circuit has two controls; a front panel pushbutton and a rear panel connection. priority is given to the rear panel connection.

1. Rear panel ON/OFF Control

Contacts 9, 10 at the rear panel External Control connector (fig. 4-2, item 4) serve as ON/OFF terminals. Either short circuit or TTL '0' level enables the power supply output and open circuit or TTL '1' level disables the power supply's output. An open collector transistor can be used for the ON/OFF control as shown in fig. 4-3, with sink current ability of more than 2.5mA. Please note that pin 10 (COM) is internally connected to the - Sense potential, therefore for floating ON/OFF Control a photocoupler should be used as shown in Fig. 4-4.

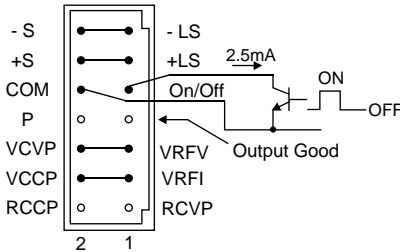

Fig. 4-3: ON/OFF Control, references to - Sense. (ZUP rear panel view)

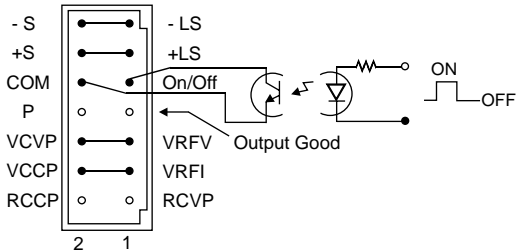

Fig. 4-4: Floating ON/OFF Control (ZUP rear panel view)

2. Front panel ON/OFF Control

The Front Panel ON/OFF is controlled by the OUT pushbutton. To enable the output, OUT pushbutton should be pressed so that OUT LED illuminates. The operation of OUT pushbutton is enabled only if the rear panel ON/OFF is configured to 'ON'.

4.4.9 Last Setting Memory

The ZUP series is equipped with Last Setting Memory which stores all power supply parameters at each ac turn-off sequence of the power supply. The OUT parameter storage is determined prior to the ac turn-off to allow two modes of re-start of the power supply.

STORED PARAMETERS

- | | |
|-------------------|---|
| 1. Output Voltage | 7. REMOTE/LOCAL |
| 2. Output Current | 8. ADDRESS |
| 3. OVP Levels | 9. Communication Standard (RS232/RS485) |
| 4. UVP Levels | 10. Baud-rate |
| 5. FOLD | 11. Service request parameters |
| 6. Re-start mode | (Items 8-10 are related to computer controlled operation and explained in chapter 5). |

1. Automatic start mode

In this mode the power supply restores its last operation setting and sets the OUT to 'ON' state. Upon start-up, the output is enabled and the power supply delivers power to the output terminals. To select this mode press and hold OUT pushbutton. After approx. 3sec., the display will continuously cycle between AS ON (auto-start on) and AS OFF (auto-start off), approx. every 3sec. Releasing the OUT pushbutton while AS ON is displayed, will set the power supply to automatic start mode. (holding OUT depressed for more than 1sec. does not change the output on/off status). In cases where the Over Voltage or Over Temperature or Foldback protection has been activated, the unit will automatically change to safe start mode after the AC voltage recycling.

2. Safe start mode

In this mode, the power supply restores its last operation setting and sets the OUT to the 'OFF' state. To select this mode, press and hold OUT pushbutton. After approx. 3sec., the display will continuously cycle between AS ON (auto-start on) and AS OFF (auto-start off), approx. every 3sec. Releasing the OUT pushbutton while AS OFF is displayed will set the power supply to safe start mode. At startup, the output is disabled and the output voltage and current are zero. To enable the output and restore the last output voltage and current values, OUT pushbutton should be momentarily pressed.

4.4.10 Output Voltage & Current programming by external resistor

1. For resistive programming, internal current sources, for output voltage and/or output current control, supply 1mA current through external programming resistors. The voltage across the programming resistors is used as a programming voltage for the power supply. Resistance of 0~4kohm programs the output from 0 to full scale (full scale is 105% of the rated voltage or current). A variable resistor can control the output over its entire range, or a combination of variable resistor and series/parallel resistors can control the output over a restricted portion of its range. Alternatively, a switch can be used to select fixed values of programming resistance to obtain a set of discrete voltages or currents. Care must be taken to avoid open circuit at the programming resistors, as it will cause over-voltage at the output. In this case, no damage to the power supply will be caused however, it is recommended to set OVP limit to a level which is safe for the load circuitry.
2. To maintain the temperature stability specification of the power supply, the resistors used for programming should be stable and low noise resistors, with temperature coefficient of less than 25ppm and power rating of 1/4W or more.
3. Where external resistor programming is used, front panel control and computer control (via serial communication) of the output voltage and current are disabled.

4. OUTPUT VOLTAGE PROGRAMMING BY EXTERNAL RESISTOR

Fig 4-5 shows a typical set-up for programming the output voltage. A variable programming resistor, 0~4Kohm produces a proportional output voltage from zero to full scale. In order to set the low limit, a series resistor can be connected to the programming resistor. For example; a 1kohm series resistor will set the lower limit to 25% of full scale. In order to set the upper limit, a resistor can be connected in parallel to the programming resistor. The resultant programming resistance of the series/parallel resistors must be between 0 and 4Kohm.

NOTE

Resistive programming is possible for local and remote sensing.

Fig. 4-5:
Constant voltage resistive programming.

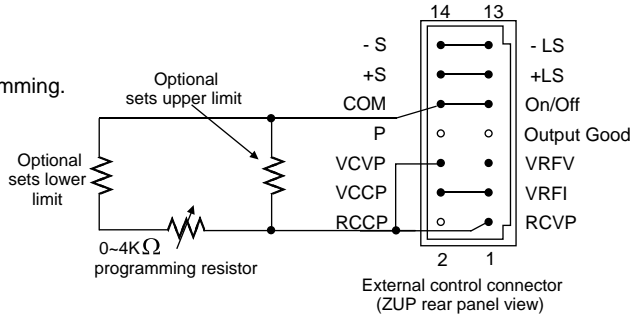

5. OUTPUT CURRENT PROGRAMMING BY EXTERNAL RESISTOR

Fig 4-6 shows the set-up for constant current resistive programming. The explanation given for constant voltage resistive programming also applies for constant current.

Fig. 4-6:
Constant current resistive programming.

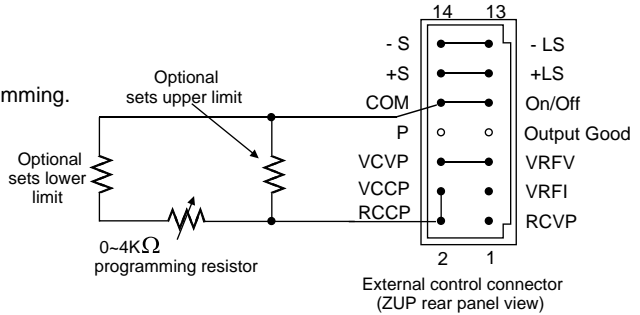

4.4.11 Output Voltage Programming by external voltage

Fig. 4-7 shows the set-up for external voltage programming of the output voltage. A voltage source variable from 0 to 4V, programs the output voltage proportionally from zero to full scale. The static load current on the programming source is less than 2uA. The source resistance should be less than 10Kohm to avoid degradation of offset and drift specifications. When external voltage is used for programming the front panel and the computer control (via the serial communication) are disabled.
 Note: Full scale is 105% of the rated output voltage.

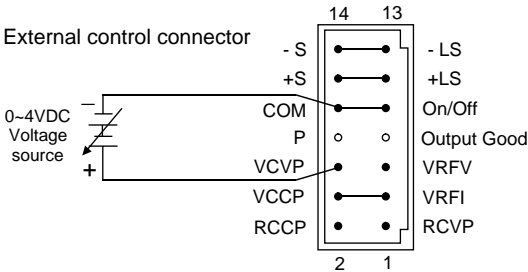

Fig. 4-7:
Output voltage programming by external voltage source. (ZUP rear panel view)

4.4.12 Output Current Programming by external voltage

Fig. 4-8 shows the set-up for external voltage programming of the output current. A voltage source variable from 0 to 4V, programs the output current proportionally from zero to full scale. The static load current on the programming source is less than 2uA. The source resistance should be less than 10Kohm to avoid degradation of offset and drift specifications.
 Note: Full scale is 105% of the rated output current.

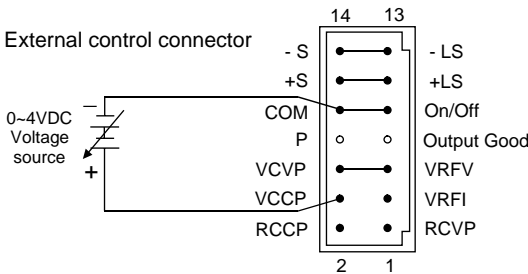

Fig. 4-8:
Output current programming by external voltage source. (ZUP rear panel view)

CAUTION

The Com pin at the external control connector is connected to the -Sense potential. NEVER connect the Com pin (pin10) to any potential, as it may damage the power supply.

CAUTION

Avoid connection of resistors greater than 4kohm or voltage greater than 4V for external resistor or voltage programming, as it may cause the output voltage and current to exceed the power supply rating. The display will NOT show the actual voltage and current when such resistor or voltage is applied for programming.

4.4.13 Auto Parallel Operation

1. Up to five units of the same rating can be connected in an auto-parallel combination to provide up to five times the output current capability. One of the power supplies operates as a master and the remaining units as slaves. The slave units are analog programmed by the master unit. At remote operation, only the master unit can be programmed by the computer while the slave units may be connected to the computer for actual voltage and current readback only.
2. Foldback protection if desired, may only be used with the master unit. When the master unit shuts down it programs the slave units to zero output voltage.
3. Setting the voltage and current:

The output voltage of the slave units should be programmed higher than the output and the master to avoid interference with the master CV control. Output voltage of the master should be programmed to the desired voltage, and the current limit to the desired load current divided by the number of parallel units. During operation, the master unit operates at CV mode and the slave units at CC mode.

4. While operating in CV mode, the master unit regulates the output voltage and the slave units operate as controlled current source, following the master output current. It is recommended to design the power system so that each unit will supply up to 95% of its current rating, because of an imbalance which may be caused by cabling and connections voltage drop.
5. **Over Voltage Protection:** The master unit OVP should be adjusted to the desired OVP level. The OVP of the slave units should be adjusted higher than the Master OVP. When the master unit shuts down, it programs the slave units to zero output voltage. If a slave unit shuts down (when its OVP is set lower than the master output voltage), only that unit will shut down and remaining slave units will supply all the load current.
6. **Connection to the Load:** At auto-parallel mode, power supplies can be connected in local or remote sensing. Refer Fig. 4-9, 4-10 & 4-11 for typical connections of paralleled power supplies. The figure below shows connection of two units, however the same connection method applies for up to 5 units.

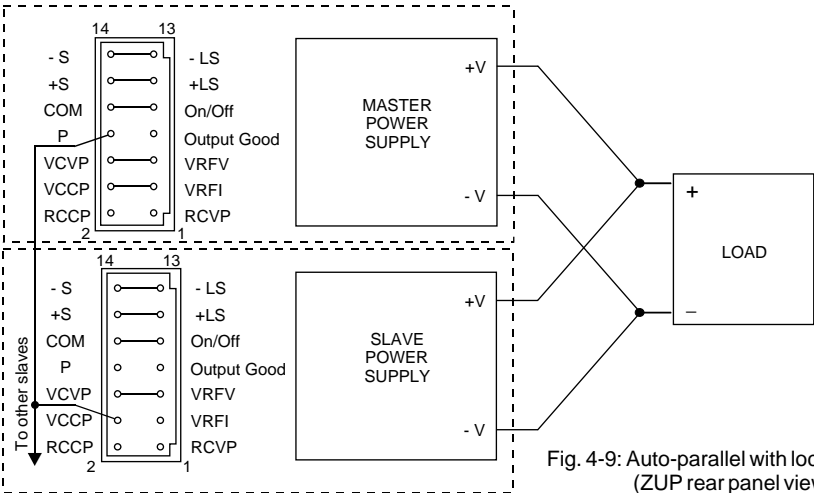

Fig. 4-9: Auto-parallel with local sensing (ZUP rear panel view)

NOTE

With local sensing it is important to minimize the wire length and resistance. Also the wires resistance should be as close as possible to achieve current balance between power supplies.

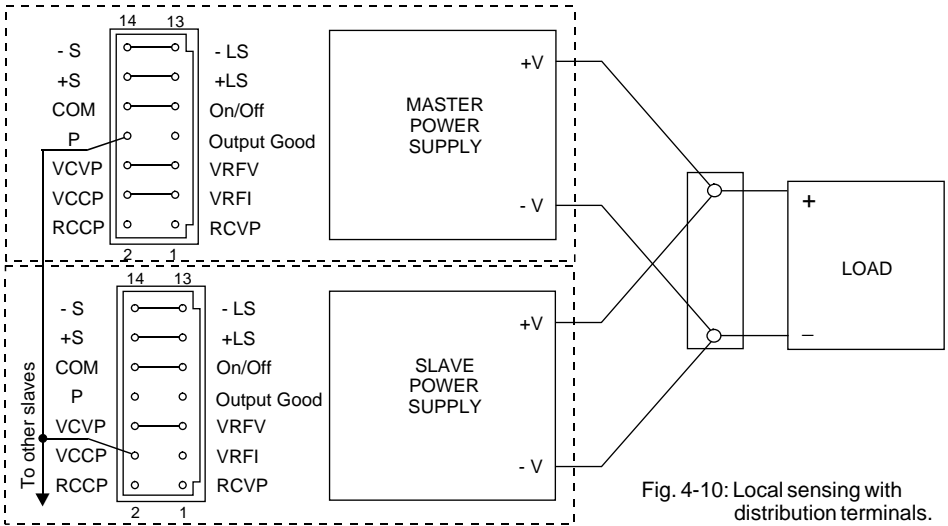

Fig. 4-10: Local sensing with distribution terminals. (ZUP rear panel view)

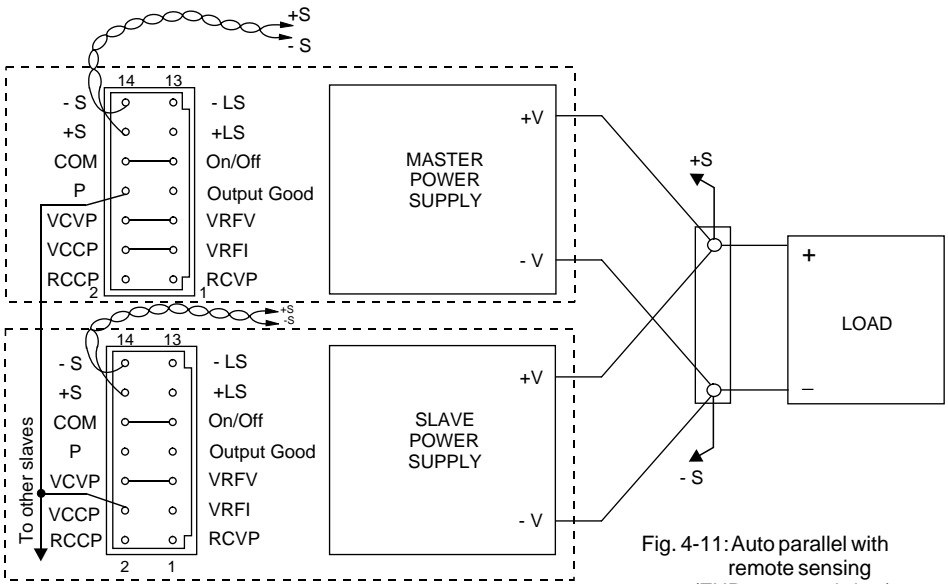

Fig. 4-11: Auto parallel with remote sensing (ZUP rear panel view)

4.4.14 Series Operation

1. GENERAL: Two power supplies of the same rating can be connected in series to increase the output voltage or to provide bipolar output voltage.

CAUTION

When two power supplies are connected in series, they should be programmed to the same output voltage to prevent damage to the lower voltage supply at short circuit condition.

2. Series connection for increased output voltage:

2.1 General: At this operation mode, two units are connected so their outputs are summed. Set the current limits of each power supply to the maximum that the load can handle without damage. It is recommended to connect diodes in parallel to each unit output to prevent reverse voltage during start-up condition or in case one of the units shuts down. Each diode should be rated to at least the power supply's output current. Refer to Fig: 4-12 and 4-13 for this operating mode.

CAUTION

When power supplies are connected in series, and the load or one of the output terminals is grounded, no point may be at a greater potential (+ or -) from ground than that specified on the front panel marking.

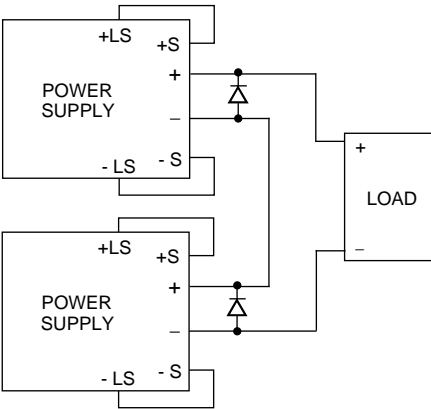

Fig. 4-12: Series connection with local sensing.

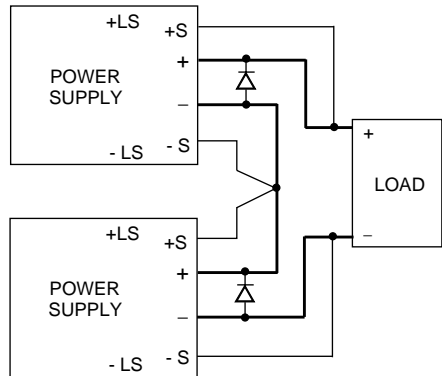

Fig. 4-13: Series connection, remote sensing.

2.2 Remote programming at series operation for increased output voltage:

1. Programming by external voltage; The analog programming circuits of the ZUP power supply are referenced to the -Sense potential. Therefore, the circuits used to control each unit must be separated and floated from each other.
2. Programming by external resistor: Programming by external resistor is possible. Refer to Fig. 4-5 and Fig. 4-6 for details.
3. Programming via the communication port (RS232/RS485): The communication port is isolated from the output voltage, therefore power supplies connected in series, can be chained using the Remote-in and Remote-out connectors.

3. Series connection for bipolar output voltage:

3.1 General: At this operation mode, two units are configured as a bipolar voltage/current source. Set the current limits of each power supply to the maximum that the load can handle without damage. It is recommended to connect diodes in parallel to each unit output to prevent reverse voltage during start-up condition or in case one of the units shuts down. Each diode should be rated to at least the power supply's output current. Refer to Fig. 4-14 for this operating mode.

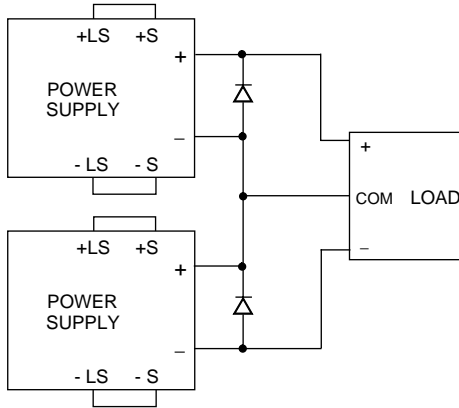

Fig. 4-14: Series connection for bipolar output

3.2 Remote programming at series operation for bipolar output voltage:

1. Programming by external voltage; The analog programming circuits of the ZUP power supply are referenced to the - Sense potential. Therefore, the circuits used to control each unit must be separated and floated from each other.
2. Programming by external resistor: Programming by external resistor is possible. Refer to Fig. 4-5 and Fig. 4-6 for details.
3. Programming via the communication port (RS232/RS485): The communication port is isolated from the output voltage, therefore the serially connected power supplies can be chained using the Remote-In and Remote-Out connectors.

4.4.15 Output Good Signal

Output Good Signal is an open collector output, referenced to COM potential, indicating the status of the power supply output. While the power supply operates normally, the Output Good is low (0–0.8V). When the power supply output is disabled due to activated OVP, OTP or FOLD protection, or by OUT set to off, or by ac ON/OFF set to off, then the output signal stops conducting. The maximum sink current is 10mA and the maximum voltage is 40VDC.

CAUTION

The Output Good Signal is referenced to the COM potential, therefore pay attention NOT to short it to another potential as it may damage the unit.

Typical applications of Output Good Signal

1. In multiple power supply systems, it is possible to disable all the units when a critical unit fails. Refer to Fig 4-15 for typical connection diagram.

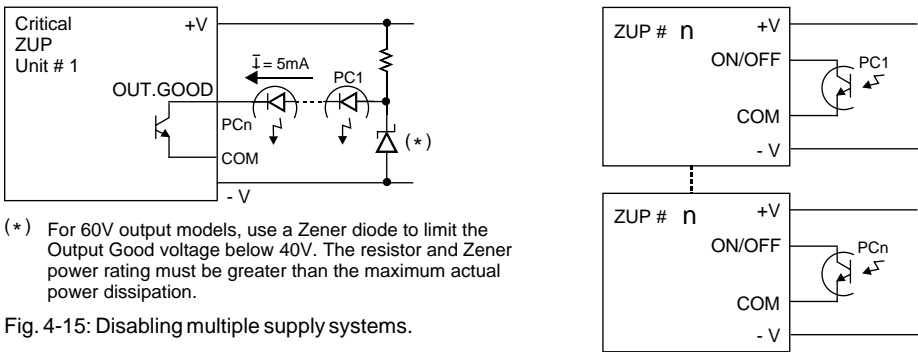

Fig. 4-15: Disabling multiple supply systems.

2. Hierarchical structure in multiple supply systems: It is possible to define a hierarchy in multiple supply systems by enabling any N+1 unit by the Output Good signal of the N unit. In this structure, failure of the N unit will cause all the following units to be disabled. Refer to Fig 4-16 for typical connections diagram.

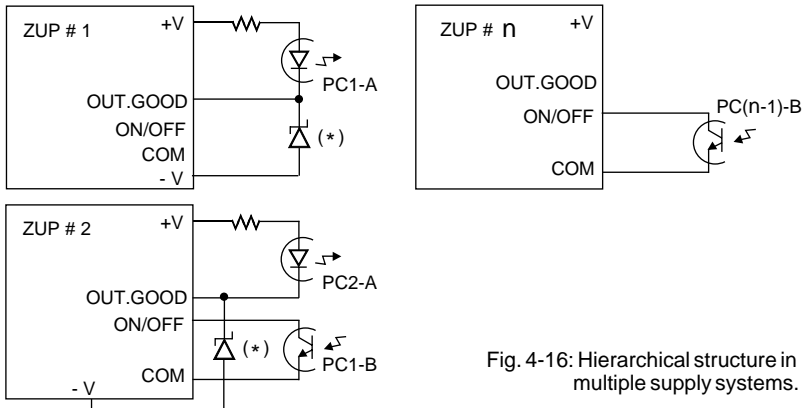

Fig. 4-16: Hierarchical structure in multiple supply systems.

CHAPTER 5 RS232 & RS485 REMOTE CONTROL

5.1 INTRODUCTION

This chapter describes the operation of the ZUP series via the serial communication port. details of the initial set-up, operation via RS232 or RS485, the command set and the communication protocol are described in this chapter.

5.2 CONFIGURATION

5.2.1 Address setting

The ZUP addresses can be set to any address between 1 and 31. Follow the procedure described below to set the address.

1. Momentarily press the ADDR pushbutton on the front panel so the ADDR LED illuminates and the VOLTS display shows 'Addr'.
2. Rotate the front panel knob. While rotating the knob the AMPS display will show the selected address. When the rotation is stopped, the address shown will be the selected address. The display will return to show the actual voltage and current approx. 3 sec. from termination of rotating knob.
3. While the unit is in operation, depressing the ADDR pushbutton will cause the display to show the selected address.

5.2.2 RS232 or RS485 selection

To select between RS232 or RS485 serial communication the following steps should be taken.

1. Press and hold REM pushbutton. (holding REM depressed for more than 1sec does not change the local/remote status).
2. Press and hold REM pushbutton. After approx. 3sec. the display will continuously cycle between 'rs232' and 'rs485' approx. every 3sec.
3. To select RS232, release the REM pushbutton while 'rs232' is displayed. To select RS485, release the REM pushbutton while 'rs485' is displayed.
4. Approx. 3sec after releasing the REM, the display returns to show the actual voltage and current.

5.2.3 Baud rate setting

Six optional rates are possible: 300, 600, 1200, 2400, 4800, 9600. To select the desired rate, the following steps should be taken. The power supply should be at Local operation mode during the following procedure:

1. Press and hold ADDR pushbutton. After approx. 3 sec. the display will continuously cycle between the six optional rates approx. every 2 seconds.
2. To select the desired rate, release ADDR while that rate is displayed.
3. After releasing ADDR the display will return to show the actual voltage and current.

5.2.4 Local/Remote selection

To enable the operation via RS232 or RS485, the power supply should be at Remote mode. At this mode, all the front panel functions are disabled except Local/Remote pushbutton.

Transition from Local to Remote control:

1. Via the front panel: Momentarily press REM pushbutton so the REM LED illuminates. To return from Remote to Local control, momentarily press REM pushbutton so the REM LED extinguishes.
2. Via the serial communication port (RS232/RS485): By sending a :RMTn; command to the power supply. Refer to par. 5.5.2.

5.3 REMOTE PROGRAMMING VIA RS232

5.3.1 Introduction

The RS232 interface is accessible through the rear panel IN/OUT jacks. The jacks are 8 contacts each and conform to EIA/TIA-568A requirements. The IN and OUT jacks are used to connect the units in a RS232 or RS485 chain to a controller. The data format is ASCII, 8 bits/character no parity bit, one stop bit. The baud rate can be selected to one of the 6 possible rates between 300 and 9600bps (refer to par. 5.2.3). Refer to par. 5.6 for detailed explanation.

Up to 31 ZUP units can be connected to the RS232 control as shown in Fig. 5-1.

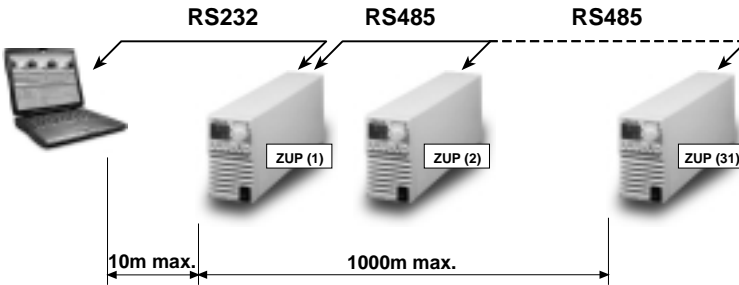

Fig. 5-1: Linking ZUP units with RS232 control.

5.3.2 Rear panel connectors pinout

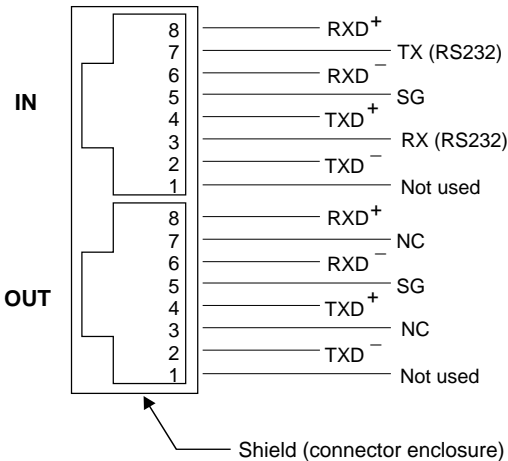

Fig. 5-2:
Rear panel connector pinout
(ZUP rear panel view)

NOTE

Tx and Rx are used for RS232 communication. Txd +/- and Rxd +/- are used for RS485 communication. Refer to RS232 and RS485 cables description for connection details.

5.3.3 RS232 cable (PC to ZUP) - NC403 , NC401

The RS232 is used only for connecting the power supply to the controller PC. For linking several power supplies, refer to par. 5.3.4.

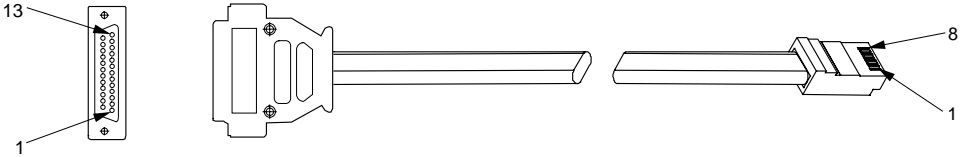

Fig. 5-3: RS232 cable with DB-25 connector - NC403

25 PIN CONNECTOR		8 PIN CONNECTOR		REMARKS
PIN NO.	NAME	PIN NO.	NAME	
1	SHIELD	3	RX	TWISTED PAIR
2	TX	7	TX	
3	RX	5	SG	
7	SG			

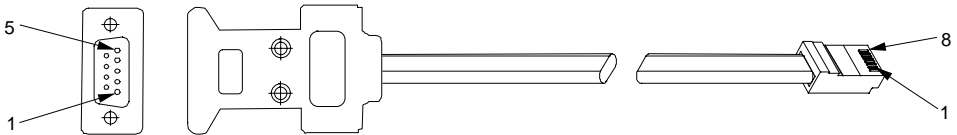
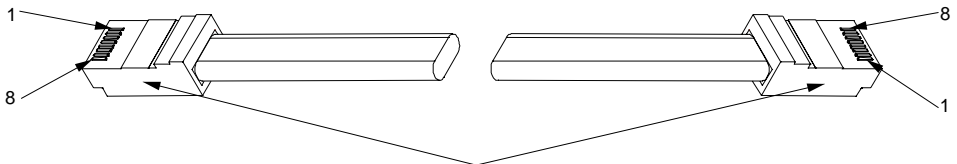

Fig. 5-4: RS232 cable with DB-9 connector - NC401.

9 PIN CONNECTOR		8 PIN CONNECTOR		REMARKS
PIN NO.	NAME	PIN NO.	NAME	
HOUSING	SHIELD	HOUSING	SHIELD	TWISTED PAIR
2	RX	7	TX	
3	TX	3	RX	
5	SG	5	SG	

5.3.4 Linking power supplies - NC405

It is possible to link up to 31 ZUP units, using rear panel In/Out connectors and linking cables as shown in Fig. 5-1. The first unit communicates with the PC via RS232 as shown in Figs. 5-3 and 5-4. The other units are linked by RS485 interface. Construction of the linking cable is shown in Fig. 5-5.



EIA/TIA-568A SHIELDED CONNECTORS

Fig. 5-5: ZUP units linking cable.

8 PIN CONNECTOR (IN)		8 PIN CONNECTOR (OUT)		REMARKS
PIN NO.	NAME	PIN NO.	NAME	
HOUSING	SHIELD	HOUSING	SHIELD	
5	SG	5	SG	
2	TXD -	2	TXD -	
4	TXD +	4	TXD +	
6	RXD -	6	RXD -	
8	RXD +	8	RXD +	

5.4 REMOTE PROGRAMMING VIA RS485

5.4.1 Introduction

For operation environments that require high noise immunity or long distance communication, it is recommended to use the built-in RS485 interface. The RS485 interface is accessible through the rear panel In/Out jacks in a similar way to the RS232. The communication is a four-wire type. Refer to par. 5-6 for detailed explanation. Up to 31 ZUP units can be connected to the RS485 control as shown in Fig. 5-6.

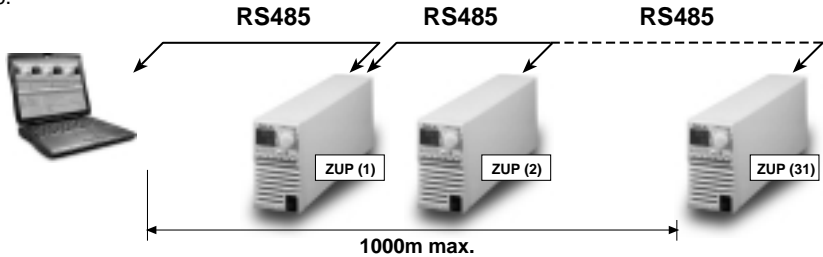

Fig. 5-6: Linking ZUP units to RS485 control.

5.4.2 RS485 cable (PC to ZUP) - NC402



Fig. 5-7: RS485 cable with DB-9 connector.

9 PIN CONNECTOR		8 PIN CONNECTOR		REMARKS
PIN NO.	NAME	PIN NO.	NAME	
HOUSING	SHIELD	HOUSING	SHIELD	
9	TXD -	6	RXD -	TWISTED PAIR
8	TXD +	8	RXD +	
1	SG	5	SG	TWISTED PAIR
5	RXD -	2	TXD -	
4	RXD +	4	TXD +	

5.4.3 Linking power supplies

Power supplies are linked in the same way as described in par. 5.3.4.

5.5 ZUP SERIES COMMAND SET DESCRIPTION

The ZUP command set is divided into four categories as follows: 1. ID Control

2. Initialization Control

3. Output Control

4. Status Control

The commands structure, syntax, and registers definition are described in this paragraph as listed above.

5.5.1 ID control commands

#	Commands	Description
1	:MDL?;	Returns the power supply model identification as an ASCII string: Nemic-Lambda ZUP(XXV)-(YYA). XX - The rated output voltage YY - The rated output current example: Nemic-Lambda ZUP(6V-33A)
2	:REV?;	Returns the software version as an ASCII string: VerXX-YY A.B XX- The rated output voltage YY- The rated output current A.B- Version identifier example: Ver6-33 1.0

5.5.2 Initialization control

#	Commands	Description
1	:DCL;	Clears the communication buffer and the following registers: 1. Operational status register 2. Alarm (fault) status register 3. Programming error register
2	:ADRn;	Sets the power supply address. ADR is followed by the address which can be 01 to 31.
3	:RMTn;	Sets the power supply to local or remote mode. (This command is active when the unit is either in Local or Remote modes). Transition from Local to Remote mode is made via the front panel only. :RMT0; Transition from Remote to Local mode. :RMT1; Transition from latched Remote to non-latched Remote. :RMT2; Latched remote: Transition back to Local mode or to non-latched Remote can be made via the serial port (RS232/485). At this mode, the front panel Local/Rem function is disabled. Escape from this mode to non-latched remote mode can be made by turning the AC ON/OFF to OFF and after approx. 10sec.to ON again.
4	:RMT?;	Returns the remote/local setting. The returned data is an ASCII string. RM1 (The unit is in remote mode) RM2 (The unit is in latched remote mode)

5.5.3 Output control

#	Commands	Description																																																
1	:VOLn;	<p>Sets the output voltage value in volts. This programmed voltage is the actual output at constant-voltage mode or the voltage limit at constant current mode. The range of the voltage values are as shown in table 5-1. Use all digits for voltage programming</p> <table border="1"> <thead> <tr> <th>Model</th> <th>MIN.</th> <th>MAX.</th> </tr> </thead> <tbody> <tr> <td>ZUP6-XY</td> <td>0.000</td> <td>6.000</td> </tr> <tr> <td>ZUP10-XY</td> <td>00.000</td> <td>10.000</td> </tr> <tr> <td>ZUP20-XY</td> <td>00.000</td> <td>20.000</td> </tr> <tr> <td>ZUP36-XY</td> <td>00.00</td> <td>36.00</td> </tr> <tr> <td>ZUP60-XY</td> <td>00.00</td> <td>60.00</td> </tr> </tbody> </table> <p>Note: The ZUP can accept programmed value higher by up to 5% than the table values, however it is not recommended to program power supply over the rated voltage.</p> <p>Table 5-1: Voltage programming range. Example- :VOL5.010; :VOL08.500;</p>	Model	MIN.	MAX.	ZUP6-XY	0.000	6.000	ZUP10-XY	00.000	10.000	ZUP20-XY	00.000	20.000	ZUP36-XY	00.00	36.00	ZUP60-XY	00.00	60.00																														
Model	MIN.	MAX.																																																
ZUP6-XY	0.000	6.000																																																
ZUP10-XY	00.000	10.000																																																
ZUP20-XY	00.000	20.000																																																
ZUP36-XY	00.00	36.00																																																
ZUP60-XY	00.00	60.00																																																
2	:VOLI;	<p>Returns the string SV followed by the present programmed output voltage value. The actual voltage range is as shown in table 5-1. example: SV5.010 SV08.500</p>																																																
3	:VOL?;	<p>Returns the string AV followed by the actual output voltage. The actual voltage range is the same as the programming range. example: AV5.010 AV08.500</p>																																																
4	:CURn;	<p>Sets the output current in Amperes. This programmed current is the actual output current at constant-current mode or the current limit at constant voltage mode. The programming range is shown in table 5-2: Use all digits for current programming.</p> <table border="1"> <thead> <tr> <th>Model</th> <th>MIN.</th> <th>MAX.</th> </tr> </thead> <tbody> <tr> <td>ZUP6-33</td> <td>00.00</td> <td>33.00</td> </tr> <tr> <td>ZUP6-66</td> <td>00.00</td> <td>66.00</td> </tr> <tr> <td>ZUP6-132</td> <td>000.00</td> <td>132.00</td> </tr> <tr> <td>ZUP10-20</td> <td>00.000</td> <td>20.000</td> </tr> <tr> <td>ZUP10-40</td> <td>00.00</td> <td>40.00</td> </tr> <tr> <td>ZUP10-80</td> <td>00.00</td> <td>80.00</td> </tr> <tr> <td>ZUP20-10</td> <td>00.000</td> <td>10.000</td> </tr> <tr> <td>ZUP20-20</td> <td>00.000</td> <td>20.000</td> </tr> <tr> <td>ZUP20-40</td> <td>00.00</td> <td>40.00</td> </tr> <tr> <td>ZUP36-6</td> <td>0.000</td> <td>6.000</td> </tr> <tr> <td>ZUP36-12</td> <td>00.000</td> <td>12.000</td> </tr> <tr> <td>ZUP36-24</td> <td>00.000</td> <td>24.000</td> </tr> <tr> <td>ZUP60-3.5</td> <td>0.000</td> <td>3.500</td> </tr> <tr> <td>ZUP60-7</td> <td>0.000</td> <td>7.000</td> </tr> <tr> <td>ZUP60-14</td> <td>00.000</td> <td>14.000</td> </tr> </tbody> </table> <p>Note: The ZUP can accept values higher by 5% than the rating. It is recommended to set the output current to 105% of the rating if the unit is required to supply the rated current.</p> <p>Table 5-2: Current programming range. Example- :CUR3.000; :CUR07.50;</p>	Model	MIN.	MAX.	ZUP6-33	00.00	33.00	ZUP6-66	00.00	66.00	ZUP6-132	000.00	132.00	ZUP10-20	00.000	20.000	ZUP10-40	00.00	40.00	ZUP10-80	00.00	80.00	ZUP20-10	00.000	10.000	ZUP20-20	00.000	20.000	ZUP20-40	00.00	40.00	ZUP36-6	0.000	6.000	ZUP36-12	00.000	12.000	ZUP36-24	00.000	24.000	ZUP60-3.5	0.000	3.500	ZUP60-7	0.000	7.000	ZUP60-14	00.000	14.000
Model	MIN.	MAX.																																																
ZUP6-33	00.00	33.00																																																
ZUP6-66	00.00	66.00																																																
ZUP6-132	000.00	132.00																																																
ZUP10-20	00.000	20.000																																																
ZUP10-40	00.00	40.00																																																
ZUP10-80	00.00	80.00																																																
ZUP20-10	00.000	10.000																																																
ZUP20-20	00.000	20.000																																																
ZUP20-40	00.00	40.00																																																
ZUP36-6	0.000	6.000																																																
ZUP36-12	00.000	12.000																																																
ZUP36-24	00.000	24.000																																																
ZUP60-3.5	0.000	3.500																																																
ZUP60-7	0.000	7.000																																																
ZUP60-14	00.000	14.000																																																

5.5.3 Output control continued

#	Commands	Description																		
5	:CUR!;	Returns the string SA followed by the present programmed output current. The programmed value range is shown in table 5-2. example- SA3.000 SA07.50																		
6	:CUR?;	Returns the string AA followed by the actual output current. The actual current range is the same as the programming range. example- AA3.000 AA07.50																		
7	:OUTn;	Sets the output to On or Off. :OUT1; - Output On :OUT0; - Output Off																		
8	:OUT?;	Returns OT followed by the output On/Off status. OT1 - Output is On OT0 - Output is Off																		
9	:FLDn;	Sets the Foldback protection to On or Off. :FLD1; Arm the foldback protection. :FLD0; Release the foldback protection. :FLD2; Cancel the foldback protection. When the foldback protection is activated, :FLD0; will release the protection and re-arm it while :FLD2; will cancel the protection. If the protection has not been activated, both commands are the same.																		
10	:FLD?;	Returns FD followed by the Foldback protection status. FD1 - Foldback is armed FD0 - Foldback is released																		
11	:OVPn;	Sets the over-voltage protection level in volts. Over-voltage range settings are given in table 5-3: <table border="1" data-bbox="333 949 584 1109"> <thead> <tr> <th>Model</th> <th>MIN.</th> <th>MAX.</th> </tr> </thead> <tbody> <tr> <td>ZUP6-XY</td> <td>0.00</td> <td>7.50</td> </tr> <tr> <td>ZUP10-XY</td> <td>00.0</td> <td>13.0</td> </tr> <tr> <td>ZUP20-XY</td> <td>00.0</td> <td>24.0</td> </tr> <tr> <td>ZUP36-XY</td> <td>00.0</td> <td>40.0</td> </tr> <tr> <td>ZUP60-XY</td> <td>00.0</td> <td>66.0</td> </tr> </tbody> </table> Table 5-3: Over-voltage programming range. example- :OVP08.4;	Model	MIN.	MAX.	ZUP6-XY	0.00	7.50	ZUP10-XY	00.0	13.0	ZUP20-XY	00.0	24.0	ZUP36-XY	00.0	40.0	ZUP60-XY	00.0	66.0
Model	MIN.	MAX.																		
ZUP6-XY	0.00	7.50																		
ZUP10-XY	00.0	13.0																		
ZUP20-XY	00.0	24.0																		
ZUP36-XY	00.0	40.0																		
ZUP60-XY	00.0	66.0																		
12	:OVP?;	Returns the string OP followed by the present programmed over-voltage protection value. The over-voltage range is given in table 5-3. example- OP08.4																		

5.5.3 Output control continued

#	Commands	Description																		
13	:UVPn;	<p>Sets the under-voltage protection limits in volts. Under-voltage range settings are given in table 5-4:</p> <table border="1"> <thead> <tr> <th>Model</th> <th>MIN.</th> <th>MAX.</th> </tr> </thead> <tbody> <tr> <td>ZUP6-XY</td> <td>0.00</td> <td>5.98</td> </tr> <tr> <td>ZUP10-XY</td> <td>0.00</td> <td>9.97</td> </tr> <tr> <td>ZUP20-XY</td> <td>00.0</td> <td>19.9</td> </tr> <tr> <td>ZUP36-XY</td> <td>00.0</td> <td>35.9</td> </tr> <tr> <td>ZUP60-XY</td> <td>00.0</td> <td>59.8</td> </tr> </tbody> </table> <p>Table 5-4: Under-voltage programming range.</p> <p>example- :UVP07.3;</p>	Model	MIN.	MAX.	ZUP6-XY	0.00	5.98	ZUP10-XY	0.00	9.97	ZUP20-XY	00.0	19.9	ZUP36-XY	00.0	35.9	ZUP60-XY	00.0	59.8
Model	MIN.	MAX.																		
ZUP6-XY	0.00	5.98																		
ZUP10-XY	0.00	9.97																		
ZUP20-XY	00.0	19.9																		
ZUP36-XY	00.0	35.9																		
ZUP60-XY	00.0	59.8																		
14	:UVP?;	<p>Returns the string UP followed by the present programmed under-voltage protection value. The under-voltage range is given in table 5-4.</p> <p>example- UP07.3</p>																		
15	:ASTn;	<p>Sets the auto-restart mode to On or Off.</p> <p>:AST1; - Auto-restart is On</p> <p>:AST0; - Auto-restart is Off</p>																		
16	:AST?;	<p>Returns the string AS followed by the auto-restart mode status.</p> <p>AS1 - Auto-restart is ON</p> <p>AS0 - Auto-restart is Off</p>																		

5.5.4 Status control

5.5.4.1 Registers structure

1. Operational Status Register:

The operational status register records signals that are part of the power supply's normal operation. In addition to the normal operation data, the register holds an alarm bit which indicates that one of the alarm (fault) register bits is set. The register is automatically updated and reading it does not change it's content. Clearing the register is done by DCL command. See table 5-5 for Operational Status Register content.

Bit Name	Bit No	Meaning
cc/cv	1	'0' - Indicates constant voltage, '1' - constant current.
fold	2	'1' - Indicates foldback protection is armed.
ast	3	'1' - Indicates auto-restart is on, '0' - auto-restart is off.
out	4	'1' - Indicates output is on , '0' -output is off.
srf	5	'0' - Indicates foldback protection SRQ is disabled , '1' - enabled.
srv	6	'0' - Indicates over voltage protection SRQ is disabled , '1' - enabled.
srt	7	'0' - Indicates over temp. protection SRQ is disabled , '1' - enabled.
alarm	8	'1' - Indicates that an alarm register bit is set. (note*1)

Table 5-5: Operational status register content.

Note:

*1 In case of AC fail, the alarm status register 'AC fail' bit will be set but will not set the alarm bit.

2. Alarm Status Register:

The alarm status register records fault conditions occurring during power supply operation. Any set bit in this register causes the 'alarm' bit in the operational status register to be set. Reading the register does not change it's content. The register is cleared by :DCL; command.

Bit Name	Bit No	Meaning
ovp	1	'1' - Indicates that the over-voltage protection was tripped (*3)
otp	2	'1' - Indicates that the over-temperature protection was tripped (*3)
a/c fail	3	'1' - Indicates that a failure occurred at the input voltage supply (*1)
fold	4	'1' - Indicates that the foldback protection was activated (*2)
prog	5	'1' - Indicates a programming error has occurred (*3)

Table 5-6: Alarm status register content.

Notes: (*1) Since at each AC turn off the AC fail bit is generated and stored, it is recommended to send a :DCL; command following application of AC voltage to the power supply, to clear the alarm status register.

(*2) FOLD bit is automatically reset upon cancellation of FOLD protection.

(*3) OVP, OTP and 'prog' bits reset at AC turn-off or by :DCL; command.

In case the OTP or OVP is triggered, the front panel control is disabled until the AC input is recycled by turning the AC ON/OFF switch to OFF and after approx. 10 sec. to ON.

3. Error Codes Register:

The error codes register records errors that occurred during the programming of the power supply. Any set bit in this register causes the 'prog' bit in the alarm status register to be set. Reading the register does not change it's content. The register is cleared by :DCL; command.

Bit Name	Bit No	Meaning
not used	1	
wrong command	2	'1' - Indicates that an unknown string was received
buffer overflow	3	'1' - Indicates an overflow in the communication buffer
wrong voltage	4	'1' - Indicates an attempt to program the power supply to a voltage out of specification limits.
wrong current	5	'1' - Indicates an attempt to program the power supply to a current out of specification limits.

Table 5-7: Error codes register content.

5.5.4.2 Status control commands

#	Commands	Description
1	:STA?;	Reads the operational status register content. Returns the string OS followed by ASCII characters representing the register's content. Refer to table 5-5 for the register content description. example- OS00010000
2	:ALM?;	Reads the alarm status register content. Returns the string AL followed by ASCII characters representing the register's content. Refer to table 5-6 for the register content description. example- AL00000

5.5.4.2 Status control commands continued

#	Commands	Description
3	:STP?;	<p>Reads the programming error register content. Returns the string PS followed by ASCII characters representing the register's content. Refer to table 5-7 for the register content description. example- PS00000</p>
4	:STT?;	<p>Reads the complete status of the power supply. This query returns ASCII characters representing the following data: AV<actual voltage > SV<voltage setting> AA<actual current> SA<current setting> OS<operational status register> AL<alarm status register> PS<programming error register></p> <p>example: AV5.010SV5.010AA00.00SA24.31OS00010000AL00000PS00000</p>

5.6 COMMUNICATION PROTOCOL

5.6.1 General Information

The average command processing time of the ZUP Series is 15mSec. It is not recommended to send strings of commands to the ZUP power supply without considering the processing time.

For query commands (? , !) , wait until the ZUP reply message has been completed , before sending a new command.

5.6.2 Accessing a ZUP Unit

The default condition of the ZUP series is Listen mode. In order to access a ZUP unit, for sending a command or query, the address of that unit should be sent by the host controller (:ADRn;). The ZUP that recognizes it's address becomes active and can communicate with the host controller. The other units remain in Listen mode, waiting to receive their address. To access another unit, the controller should send the address of that unit. The previously active unit changes it's state to Listen mode and the addressed unit becomes active.

5.6.3 End of Message

Each message sent by the ZUP is terminated by an end of message.

< CR > carriage return character

< LF > line feed character

5.7 SERVICE REQUEST

5.7.1 Service Request (SRQ)

Service request is a message generated by the ZUP power supply to interrupt the controller. SRQ can be generated by a power supply fault condition.

Each of the following conditions can generate SRQ message:

1. Over Voltage Protection (OVP).
2. Over Temperature Protection (OTP).
3. Foldback Protection.

The operator decides which of the conditions are defined as faults. Enabling or disabling a condition from generating SRQ message does not affect the condition within the power supply.

5.7.2 Service Request message

The service request message consists of three characters terminated by EOS<CR><LF>.

The first character identifies the SRQ cause: 1-Foldback , 2-OVP , 3-OTP.

The 2'nd and 3'rd characters identify the ZUP power supply address.

Example: String generated by a ZUP unit :120<CR><LF> , means foldback protection was activated in power supply address 20.

5.7.3. Service request enable/disable commands

#	Command	Description
1	:SRVn;	Enable or disable OVP service request. :SRV1; Enable OVP service request. :SRV0; Disable OVP service request.
2	:SRV?;	Returns QV followed by the OVP service request status. :QV1; OVP service request enabled. :QV0; OVP service request disabled.
3	:SRTn;	Enable or disable OTP service request. :SRT1; Enable OTP service request. :SRT0; Disable OTP service request.
4	:SRT?;	Returns QT followed by the OTP service request status. :QT1; OTP service request enabled. :QT0; OTP service request disabled.
5	:SRFn;	Enable or disable Foldback protection service request. :SRF1; Enable Foldback protection service request. :SRF0; Disable Foldback protection service request.
6	:SRF?;	Returns QF followed by the Foldback protection service request status :QF1; Foldback protection service request enabled. :QF0; Foldback protection service request disabled.

CHAPTER 6 MAINTENANCE

6.1 INTRODUCTION

This chapter contains maintenance and calibration information for the ZUP power supply series.

6.2 UNITS UNDER WARRANTY

Units requiring repair during the warranty period should be returned to a Nemic-Lambda authorized service facility. Refer to the address listing on the back cover of this user's manual. Unauthorized repairs performed by other than authorized service facilities may void the warranty.

6.3 PERIODIC MAINTENANCE

No routine maintenance of the ZUP power supply is required except for periodic cleaning. To clean, disconnect the unit from the AC supply and allow 30sec for discharging internal voltage. The front panel and the metal surfaces should be cleaned using a dry cloth. Use low pressure compressed air to blow dust from the unit.

6.4 ADJUSTMENT AND CALIBRATION

No internal adjustment or calibration are required. Units that are returned for service will be calibrated at the service facility. There is NO REASON to open the ZUP cover.

6.5 PART REPLACEMENT AND REPAIRS.

As repairs are made only by the manufacturer of authorized service facilities, no part replacement information will be discussed here. In case of failure, unusual or erratic operation of the unit, contact a Nemic-Lambda sales or service facility nearest you. Please refer to the Nemic-Lambda sales offices listed on the back cover of this user's manual.

6.6 FUSE RATINGS

ZUP 200 Series (ZUP6-33, ZUP10-20, ZUP20-10, ZUP36-6, ZUP60-3.5): T8A 250V

ZUP 400 Series (ZUP6-66, ZUP10-40, ZUP20-20, ZUP36-12, ZUP60-7): T10A 250V

ZUP800 Series (ZUP6-132, ZUP10-80, ZUP20-40, ZUP36-24, ZUP60-14): F20A 250V

ZERO-UP USER'S MANUAL INDEX

A

ac cables	6
ac fail	46
accessories	6
address	24,26,38
adjustment	49
alarm status	46
amps display	23
auto-parallel	33
automatic start	30

B

baud rate	38
bipolar voltage	36
buffer overflow	46

C

calibration	49
communication	47
constant current	27
constant voltage	27
cooling	12
cv indicator	23
cc indicator	23

D

display	23
---------	----

E

error code	46
external resistor	31
external voltage	32

F

foldback	23, 29
fuse	2, 49

G

grounding	2
-----------	---

H

humidity	8
----------	---

I

ID control	42
initialization	42

J

jacks (front panel)	21
---------------------	----

L

last setting memory	30
linking power supplies	40
local/remote	38, 23
local sensing	14

M

multiple loads	15, 16
maintenance	49

O

operational status	45
otp	46
output good	37
over voltage	28

P

parallel operation	33
parity	46

R

rack mounting	12
remote sensing	15
registers structure	45
RS232	38, 39
RS485	38, 41
RXD	41
RX (RS232)	39

S

safe start	30
safety symbols	3
series operation	35
shield	39, 40, 41
status control	45
SRQ	48

T

TXD	41
TX (RS232)	39

U

under voltage	28
---------------	----

V

volts display	23
---------------	----

W

wire size	13
wrong command	46