

## CN100A110 SERIES

### Instruction Manual

#### BEFORE USING THE POWER SUPPLY UNIT

Be sure to read this instruction manual thoroughly before using this product. Pay attention to all cautions and warnings before using this product. Incorrect usage could lead to an electrical shock, damage to the unit or a fire hazard.

#### DANGER

- Never use this product in locations where flammable gas or ignitable substances are present.

#### WARNING

- Do not touch this product or its internal components while it is in operation, or within 5 seconds of shut down. There may be high voltage or high temperature present and you may receive an electric shock or burn.
- When the product is operating, keep your hands and face away from it as you may be injured by flying debris in the event of a fault.
- Do not make unauthorised changes to this product, otherwise you may receive an electric shock and void your warranty.
- Do not use this product in the event of the emission of smoke or abnormal smell and sound etc. It might lead to fire and/or electric shock. In such cases, please contact us. Do not attempt repair by yourself, as it is dangerous for the user.
- Do not operate these products in the presence of condensation. It might lead to fire and/or electric shock.
- Do not drop or insert anything into the product. It might lead to a failure, fire and/or electric shock.

#### CAUTION

- This power supply is designed for use within an end product such that it is accessible to SERVICE ENGINEERS only.
- Confirm connections to input/output terminals and signal terminals are correct as indicated in the instruction manual before switching on.
- Input voltage, Output current, Output power, ambient temperature and ambient humidity should be kept within specifications, otherwise the product will be damaged.
- Do not operate and store this product in an environment where condensation might occur. In such case, waterproof treatment is necessary.
- Do not use this product in environment with a strong electromagnetic field, corrosive gas or conductive substances.
- For applications which require very high reliability (Nuclear related equipment, traffic control equipment, etc.), it is necessary to provide a fail safe mechanism in the end equipment.
- The information in this document is subject to change without prior notice. Please refer to the latest version of the data sheet, etc., for the most up-to date specifications of the product.
- No part of this document may be copied or reproduced in any form without prior written consent of TDK-Lambda.
- Do not inject abnormal voltages into the output or signal of this product. The injection of reverse voltage or over voltage exceeding nominal output voltage into the output or signal terminals might cause damage to internal components.
- Operation of this product under over-current or short circuit conditions can result in damage. Failures of the product under these conditions have been assessed and are considered to be safe within the meaning of IEC/EN/UL/CSA 60950-1
- This product contains a printed circuit board utilising surface mounted devices. PCB stress such as bending, twisting etc could cause damage. Therefore, please handle with care.
- In order to maintain SELV output, the baseplate must be protectively earthed in the end application. Where the baseplate is not earthed, the output must be considered hazardous and must not be made user accessible"
- The outputs of this product may, under fault conditions, exceed SELV voltage limits. Therefore the outputs must be earthed in the end equipment to maintain SELV. If the outputs are not earthed, they must be considered hazardous and must not be made user accessible.
- These products have been assessed for use with non-isolated mains derived DC where the mains source is up to 115Vac. For mains derived DC above this source voltage and up to 250Vac, there must be isolation equivalent to reinforced insulation at the rated mains source voltage.
- The application circuits and their parameters are for reference only. Be sure to verify effectiveness of these circuits and their parameters before finalising the circuit design.
- Use an HBC external fuse to each module to ensure safe operation and compliance with the Safety Standards to which it is approved.

#### Note : CE MARKING

CE Marking when applied to a product covered by this handbook indicates compliance with the low voltage directive (2006/95/EC)

DWG. No. : C256-04-11		
APPD	CHK	DWG

## Table of Contents

### Block Diagram

### Sequence Time Chart

### Terminal Explanation

### Explanation on Specifications

1. Input Voltage Range
2. Output Voltage Adjust Range (TRM terminal)
3. Maximum Output Ripple and Noise
4. Maximum Line Regulation
5. Maximum Load Regulation
6. Over Current Protection (OCP)
7. Over Voltage Protection (OVP)
8. Over Temperature Protection (OTP)
9. Remote Sensing (+S, -S terminal)
10. ON/OFF Control (CNT terminal)
11. Parallel Operation
12. Series Operation
13. Operating Ambient Temperature
14. Operating Ambient Humidity
15. Storage Ambient Temperature
16. Storage Ambient Humidity
17. Cooling Method
18. Baseplate Temperature vs. Output Voltage Drift
19. Withstand Voltage
20. Insulation Resistance
21. Vibration
22. Shock

### Installation

1. Mounting Method
2. Heatsink Installation
3. Regarding Vibration
4. Recommended Soldering Condition
5. Recommended Cleaning Condition

### Before concluding module damage

## Block Diagram

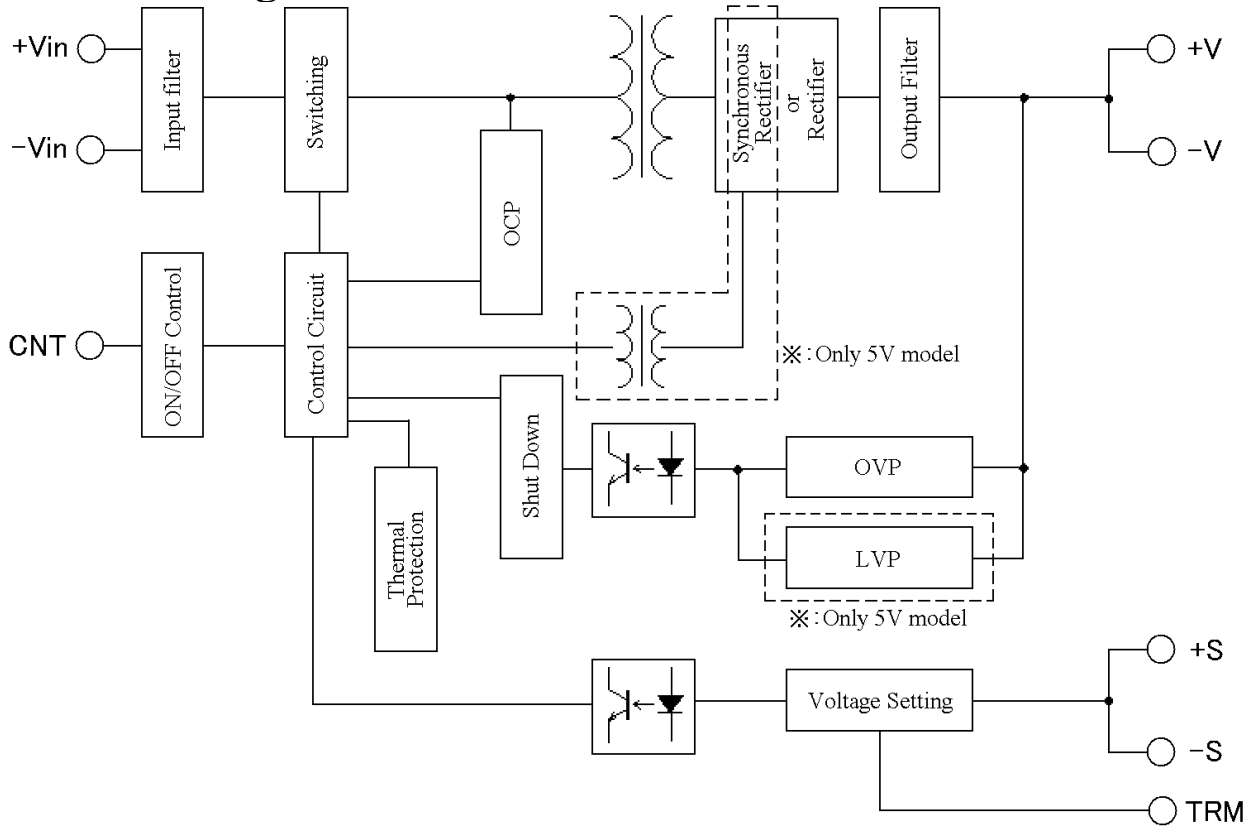

● Switching frequency(fixed) : 400kHz

## Sequence Time Chart

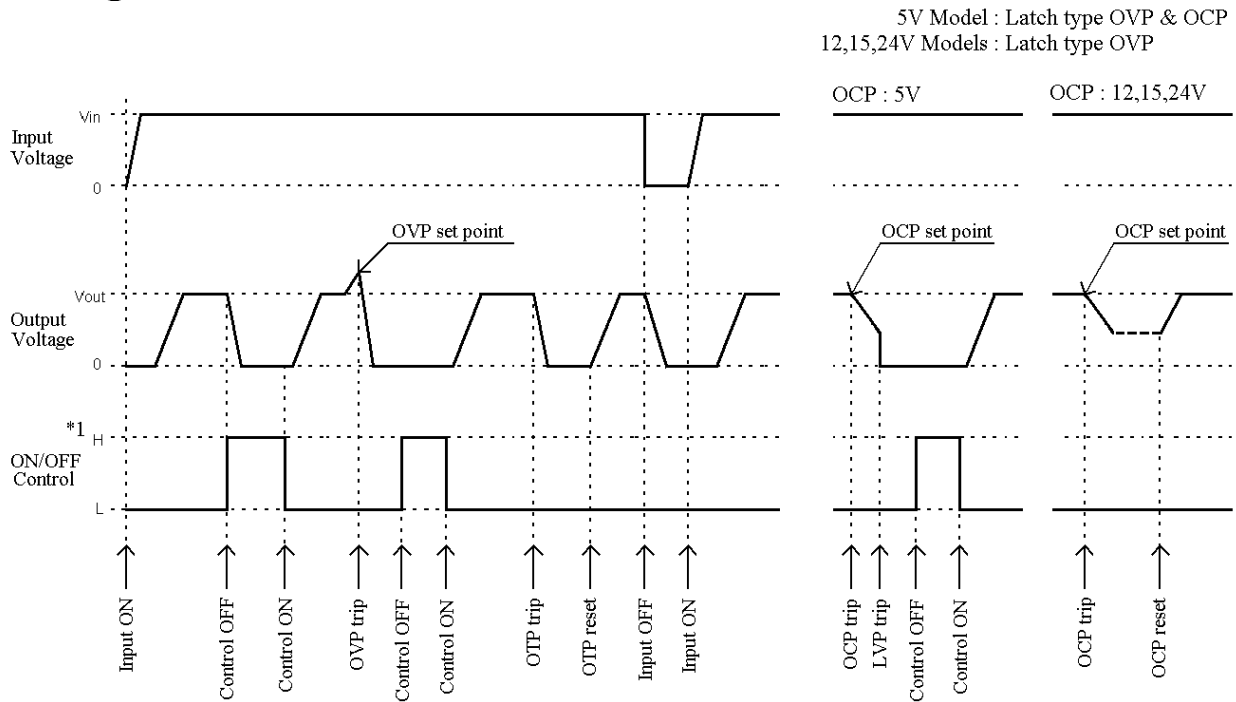

\*1 Level :  $4V \leq H \leq 35V$  or Open,  $0V \leq L \leq 0.8V$  or Short

## Terminal Explanation



### [Input Side Terminals]

- Vin : -Input Terminal
- CNT : ON/OFF Control Terminal
- +Vin : +Input Terminal

### [Output Side Terminals]

- V : -Output Terminal
- S : -Remote Sensing Terminal
- TRM : Output Voltage Trimming Terminal
- +S : +Remote Sensing Terminal
- +V : +Output Terminal

Baseplate can be connected to FG (frame ground) M3 threaded holes.

Connect +Vin, -Vin, +V, -V with consideration of contacting resistance.

## Explanations on Specifications

### 1. Input Voltage Range

Input voltage range for CN100A110 Series is indicated below.

**Input Voltage Range : 60 - 160VDC**

Basically, ripple voltage ( $V_{rpl}$ ) which results from rectification and filtering of commercial AC line is included within the input voltage as shown in Fig. 1-1. Ripple voltage must be limited within the voltage described below.

**Allowable Input Ripple Voltage : 10Vp-p**

When this value is exceeded, the output ripple voltage becomes large.

Note that sudden input voltage change may cause variation of output voltage transitionally.

Also, input voltage waveform peak value must not exceed above input voltage range.

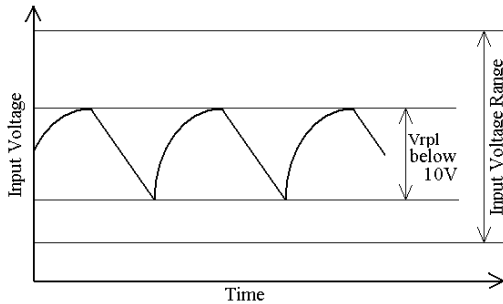

**Fig.1-1 Input Ripple Voltage**

### Basic Connection

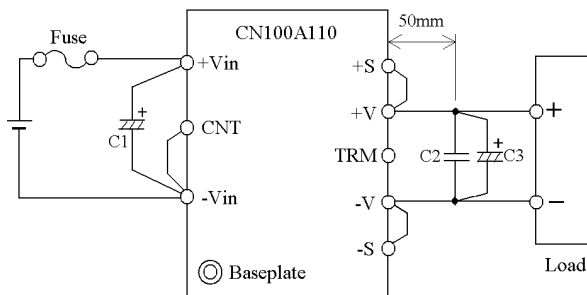

**Fig.1-2 Basic Connection**

### Input Fuse

This power module has no built-in fuse. Use external fuse to acquire various Safety Standards and to improve safety. Also, use fast-blow type or normal-blow type for every module.

Furthermore, fuse must be connected to the +Vin side if -Vin side is used as ground, or fuse must be connected to -Vin side if +Vin side is used as a ground.

### Input Fuse Recommended Current Rating:

**CN100A110 : DC450V, 5A**

### C1 : 47 $\mu$ F

To prevent the effect of input line inductance to the power module, connect electrolytic capacitor between +Vin and -Vin terminals.

Furthermore, use electrolytic capacitor with small ESR value. Especially take note that during line turn off at low ambient temperature, power module output will not normally shut down due to unstable C1 voltage.

Also, ripple current flows across this capacitor. Therefore, verify maximum allowable ripple current this capacitor when selecting component. Verify actual ripple current value by actual measurement.

**Recommended Capacitor Value : 47  $\mu$  F and above  
(Voltage Rating 200V and above)**

### Notes

1. Use low impedance electrolytic capacitor with excellent temperature characteristics.
2. When input line inductance becomes excessively high due to insertion of choke coil, operation of the power module could become unstable. For this case, increase C1 value more than the value indicated above.
3. Take note of the allowable ripple current of the capacitor to be used. Especially, when load adding capacitors for abrupt current changes, be sure to verify that ripple current does not exceed allowable ripple current before use.

## C2 : 2.2 μ F

To reduce spike noise voltage at the output, connect 2.2μF ceramic capacitor between +V and -V within 50mm distance from the output terminals.

Also, take note that output spike noise voltage could vary according to PCB wiring design.

## C3 :

For stable operation, connect a electrolytic capacitor between +V and -V within 50mm distance from the output terminals.

Take note that output ripple could be affected by electrolytic capacitor, equivalent impedance and inductance characteristics of wiring.

Take note that output ripple voltage could vary according to PCB wiring design.

For cases of abrupt changes in load current or input voltage, increasing capacitance value of the external capacitors could reduce the voltage fluctuation.

Vout	C3
5V	10V , 1000μF
12V	25V , 470μF
15V	25V , 470μF
24V	50V , 220μF

**Table1-1 C3 Recommended Values of External Output Capacitor**

Maximum capacitance (electrolytic capacitor) that can be connected between +V and -V, is shown below.

**Maximum capacitance of output capacitor  
ALL MODELS : 10,000 μ F**

### Notes

1. Use low impedance electrolytic capacitor with excellent temperature characteristics.  
(Nippon Chemi-con LXZ Series or equivalent)
2. Use two capacitors indicated above in parallel when ambient temperature becomes lower than -20 to reduce ESR.
3. Take note of the allowable ripple current of the capacitor to be used. Especially, when load adding capacitors for abrupt current changes, be sure to verify that ripple current does not exceed allowable ripple current before use.

## Reverse Input Connection

Reverse input polarity would cause module damage. For cases where reverse connections are possible, connect a protective diode and fuse. Use protective diode with higher voltage rating than the input voltage, and with higher surge current rating than the fuse.

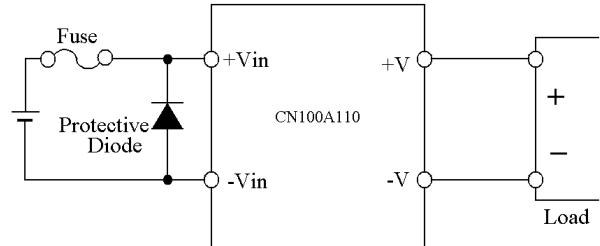

**Fig.1-3 Protection for Reversed Connection of Input**

## 2. Output Voltage Adjustment Range

**(TRM terminl)**

Output voltage could be adjusted within the range described below by external resistor or variable resistor.

However, take note that OVP might trigger when output voltage adjustment exceeds the ranges indicated below.

### Output Voltage Adjustment Range

**5V :**  
-10% - +20% of Nominal Output Voltage

**12V,15V,24V:**  
-10% - +10% of Nominal Output Voltage

When increasing the output voltage, reduce the output current accordingly so as not to exceed the maximum output power.

Take note that the output current when output voltage is decreased is rated output current of specification.

Remote sensing is possible even when output voltage is varied. For details on remote sensing function, please refer to “9.Remote Sensing”

## Output Voltage Adjustment by External Resistor or by Variable Resistor

### (1) In case of adjusting output voltage lower

(1-1) Available maximum output current = rated output current of specification.

(1-2) Connect an external resistor  $R_{adj(down)}$  between the TRM terminal and -S terminal.

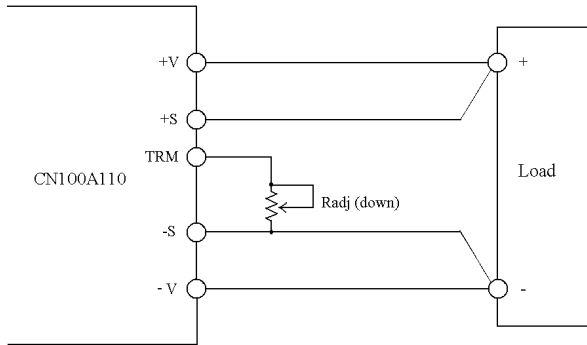

**Fig.2-1 Connection for Output Voltage Trim Down**

(1-3) Equation of external resistor and output voltage

$$R_{adj(down)} = \left( \frac{100(\%)}{\Delta(\%)} - 2 \right) [k\Omega]$$

$R_{adj(down)}$  : External adjustment resistor  
 $\Delta(\%)$  : Output voltage change rate against nominal output voltage

Below graph is relation  $\Delta(\%)$  and value of external resistor.

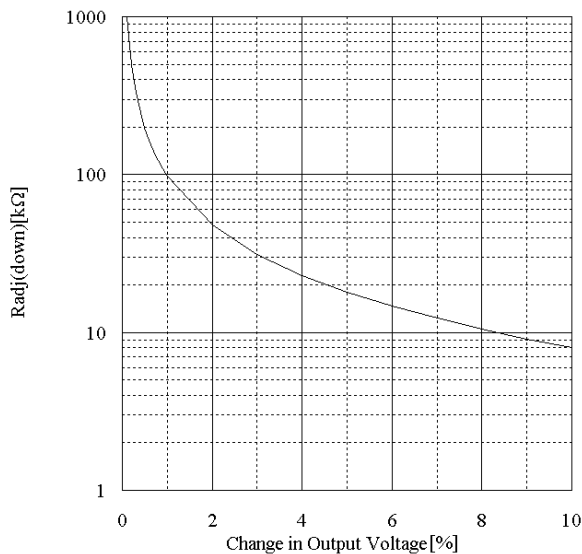
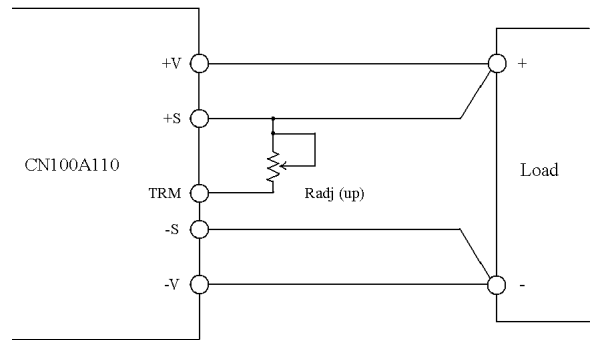

**Fig.2-2  $\Delta(\%)$  vs.  $R_{adj(down)}$  (1)**

### (2) In case of adjusting output voltage higher

(2-1) Allowable maximum output current = maximum output power ÷ output voltage (reduce maximum output current in specification.)

(2-2) Connect an external resistor  $R_{adj(up)}$  between TRM terminal and +S terminal.



**Fig.2-3 Connection for Output Voltage Trim Up**

(2-3) Equation of external resistor and output voltage

$$R_{adj(up)} = \left( \frac{V_o(100(\%) + \Delta(\%))}{1.225 \times \Delta(\%)} - \frac{100(\%)}{\Delta(\%)} - 2 \right) [k\Omega]$$

$V_o$  : Nominal output value of module  
 $R_{adj(up)}$  : External adjustment resistor  
 $\Delta(\%)$  : Output voltage change rate against nominal output voltage

Below graph is relation  $\Delta(\%)$  and value of external resistor.

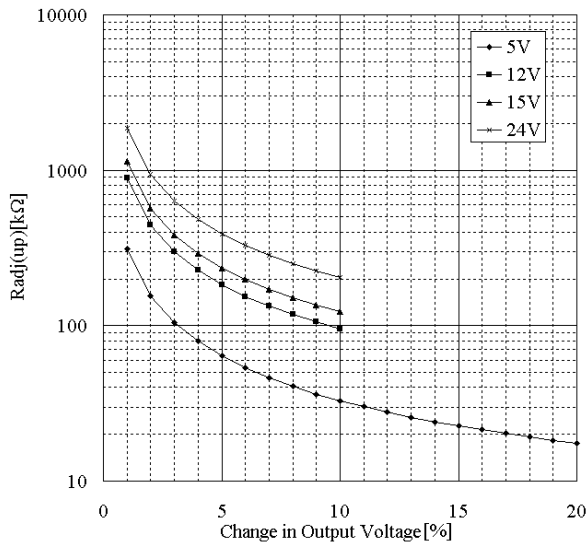

**Fig.2-4 Δ(%) vs. Radj(up) (2)**

**(3) To adjust output voltage for whole range**

Resistor values, as well as, connecting methods for external resistor (R1) and external variable resistor (VR) are described below.

	5V	12V	15V	24V
R1	5.6k	5.6k	5.6k	5.6k
VR	2k	5k	5k	10k

unit : [ Ω ]

R1 : ± 5% Tolerance  
 VR : ± 20% Tolerance  
 with end resistance below 1%

**Table 2-1 Values of External Resistor and Variable Resistor**

$\left[ \begin{array}{l} V_o : -10\% - +20\%(5V) \\ V_o : -10\% - +10\%(12V,15V,24V) \end{array} \right]$

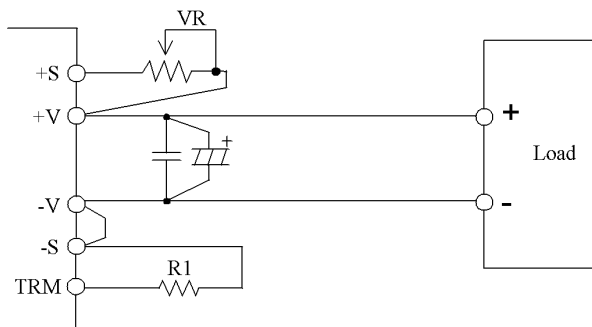

**Fig.2-5 Example of Connecting External Resistor**

**(4) Output Voltage Adjustment by applying external voltage**

By applying external voltage at the TRM terminal, output voltage can be adjusted within the same output

voltage adjustment range as the output voltage adjustment by external resistor or variable resistor. For this case, output voltage can be determined by the formula shown below.

$$\text{Output Voltage} = \text{TRM Terminal Voltage} \times \text{Nominal Output Voltage} \times 0.8163[\text{V}]$$

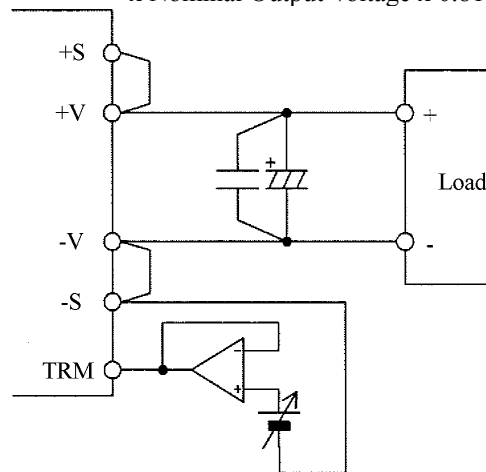

**Fig.2-6 Output Voltage Adjustment by Applying External Voltage**

For applications other than the above, refer to the TRM circuit as shown in fig.2-7 and determine external circuit and components values.

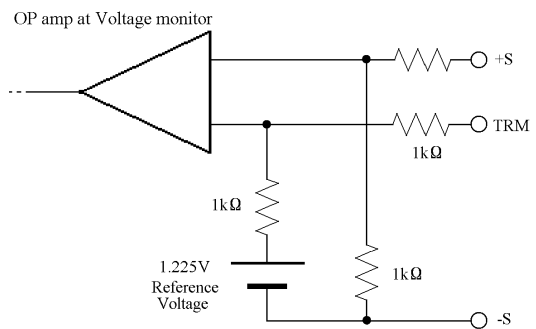

**Fig.2-7 Internal TRM Circuit (For the Reference)**

**3. Maximum Ripple and Noise**

Measured value according to the specified methods based on JEITA-9141 (Clause 7.12 and clause 7.13) which is described in the following.

Connect according to fig.3-1 and measure. Connect capacitors (C2: refer to table 3-1 for ceramic capacitor values, C3: refer to table 3-1 for electrolytic capacitor values) at 50mm distance from the output terminals. Measure at ceramic capacitor (C2) terminals as shown in fig. 3-1 using coaxial cable with JEITA attachment. Use oscilloscope with 100MHz frequency bandwidth or equivalent.



Vout	C2	C3
5V	2.2 $\mu$ F	10V , 1000 $\mu$ F
12V	2.2 $\mu$ F	25V , 470 $\mu$ F
15V	2.2 $\mu$ F	25V , 470 $\mu$ F
24V	2.2 $\mu$ F	50V , 220 $\mu$ F

**Table3-1 C2,C3 Recommended Values of External Output Capacitor**

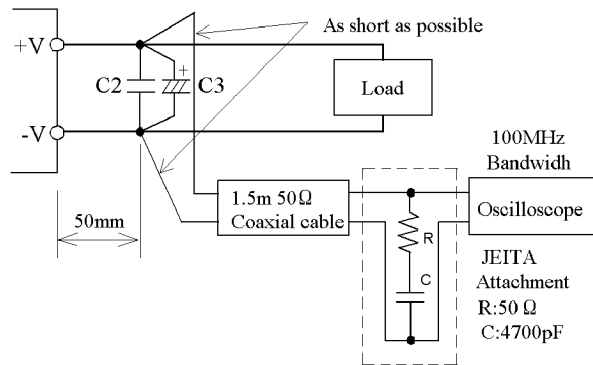

**Fig.3-1 Measurement of Maximum Output Ripple & Noise**

Take note that output ripple voltage and output spike noise may vary depending on PCB wiring design.

Generally, increasing capacitance value of external capacitor can reduce output ripple voltage and output spike noise.

#### 4. Maximum Line Regulation

Maximum value of output voltage change when input voltage is gradually varied (steady state) within specified input voltage range.

#### 5. Maximum Load Regulation

Maximum value of output voltage change when output current is gradually varied (steady state) within specified output current range.

When using at dynamic load mode, audible noise could be heard from the power module and output voltage fluctuation might increase. A thorough pre-evaluation must be performed before using this power module.

#### 6. Over Current Protection (OCP)

This power module has built-in OCP function.

When output current is overload conditions, output voltage lowers. Output will recover when short circuit or overload conditions are released. OCP setting value is fixed and therefore, can not be externally adjusted.

Take note that power module might be damaged continuing output short circuit or over load conditions depending on thermal conditions.

##### For 5V Model Only

Take note, when output voltage model drops down below lower side of adjustment range by output short circuit or over load conditions, output might be shut down. Output can be recovered by manual reset of the control ON/OFF terminal or by turning input line off and then turning it on again .

##### 5V Model

**OCP elase input voltage value : 45VDC and below**

#### 7. Over Voltage Protection (OVP)

This power module has built-in OVP function.

OVP set point is relative to the rated output voltage value. When output voltage exceed OVP set point, output voltage shut down. OVP setting value is fixed and therefore, can not be externally adjusted.

When OVP is triggered, output can be recovered by turning input line off and then turning it on again after lowering the input voltage below the voltage value indicated below or by manual reset of the control ON/OFF terminal.

**OVP release input voltage value : 45VDC and below**

When verifying OVP function by applying external voltage at the output terminals, applied voltage value should not exceed specified OVP maximum value. Refer to specification table for OVP maximum value. Avoid applying external voltage that exceeds OVP maximum value because this will cause power module damage.

#### 8. Over Temperature Protection (OTP)

This power module has built-in OTP function.

This function operates and shuts down the output

when ambient temperature or internal temperature of power module abnormally rises. OTP operates at 105 to 125 baseplate temperature. OTP can be released when baseplate temperature drops down approximately to within 100 to 120 . However, take note that OTP will operate again unless the cause of abnormal heat of the power module is eliminated.

## 9. Remote Sensing (+S, -S terminal)

Remote sensing terminal is provided to compensate for voltage drop across the wirings from the power module output terminal to the load input terminal.

When remote sensing function is not used (local sensing), short +S terminal to +V terminal and, -S terminal to -V terminal.

When using remote sensing function, output power of power module should be within maximum output power. Also, use within maximum output adjustable voltage at output terminal.

When wire is long, Power Supply operation might be unstable due to noise. Moreover, please do enough prior evaluation for remote sensing function by using shielded wire, twist pair, or parallel pattern.

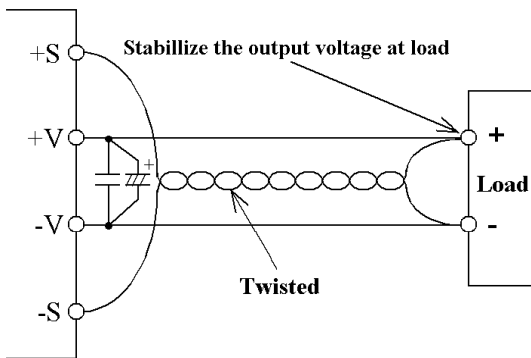

Fig.9-1 Remote Sensing is in Use

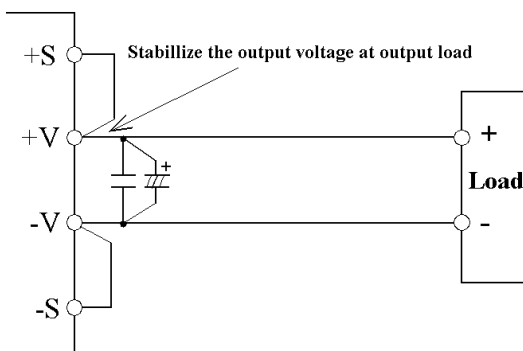

Fig.9-2 Remote Sensing is Not in Use

## 10. ON/OFF Control (CNT terminal)

Without turning the input supply on and off, the output can be enabled and disabled using this

function. This function also can be used for output sequence of plural power modules.

ON/OFF control circuit is on the primary side (the input side). For secondary control, isolation can be achieved through the use of an opto-coupler or relay.

CNT Terminal Level to -Vin Terminal	Output Status
H Level ( 4V H 35V ) or Open	OFF
L Level ( 0V L 0.8V ) or Short	ON

Table10-1 CNT Terminal Level

### Notes

1. When ON/OFF control function is not used, CNT terminal should be shorted to -Vin terminal.
2. When using long wiring, for prevention of noise, attach a capacitor between CNT terminal and -Vin terminal.
3. At L level, maximum source current from CNT terminal to -Vin terminal is 0.5mA
4. The maximum CNT terminal voltage is 35V.

### (1) Output ON/OFF control

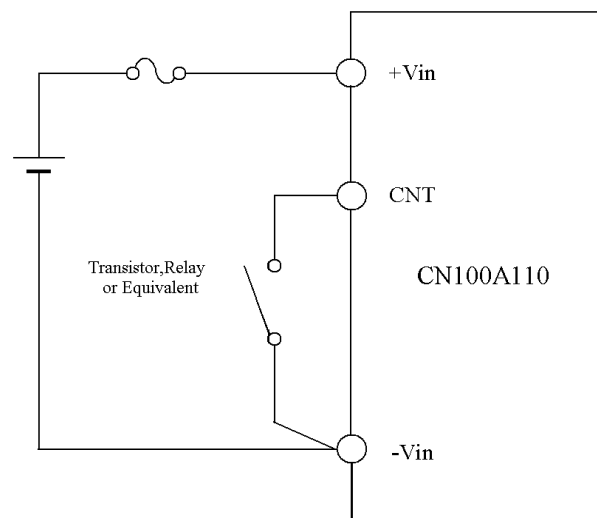
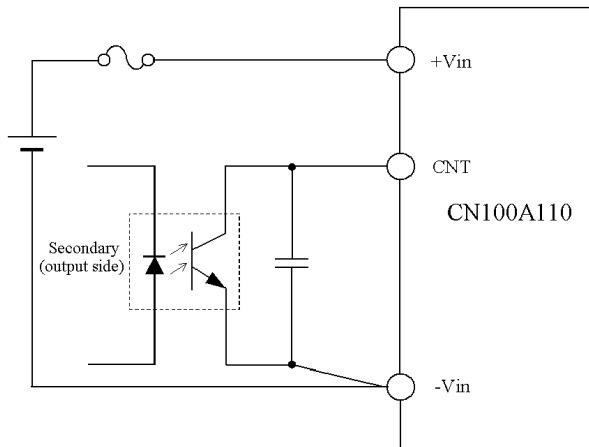

Fig.10-1 CNT Connection (1)

### (2) Secondary (output side) control



**Fig.10-2 CNT Connection (2)**

## 11. Parallel Operation

Parallel Operation can not be used.

## 12. Series Operation

Series operation is possible for CN100A110 series. Connections shown fig. 12-1 and fig. 12-2 are possible.

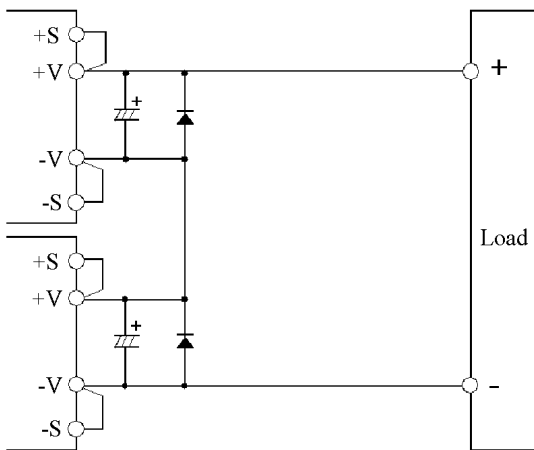

**Fig.12-1 Series Operation due to High Output Voltage**

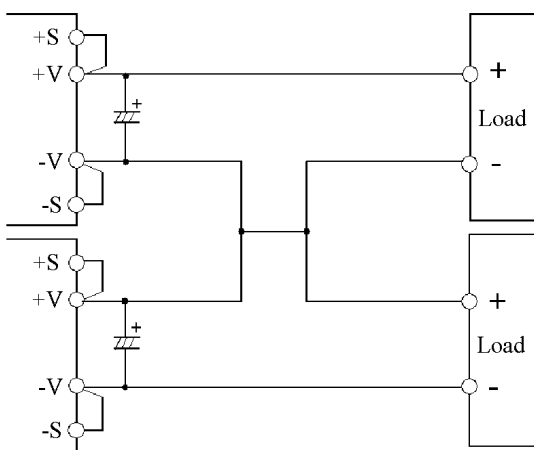

**Fig.12-2 Series Operation due to ± Output**

## 13. Operating ambient temperature

There is no restriction on mounting direction but there should be enough consideration for airflow so that heat does not accumulate around the power module vicinity. Determine external components configuration and mounting direction on PCB such that air could flow through the heatsink at forced cooling and conventional cooling.

By maintaining actual baseplate temperature below 100 °C, operation is possible.

For details on thermal design, refer to Application Notes “Thermal Design”.

Note :

Maximum baseplate temperature is 100 °C. For worst case operating condition, verify baseplate temperature at measurement point indicated in fig. 13-1.

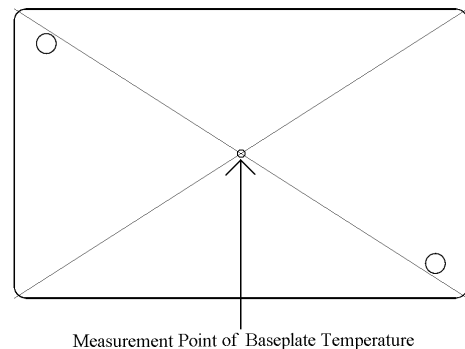

**Fig.13-1 Measurement Point of Baseplate Temperature**

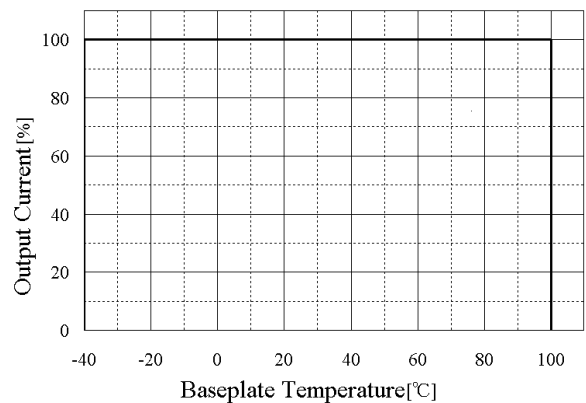

**Fig.13-2 Derating Curve**

For better improvement of power module reliability, derating of baseplate temperature when using is recommended.

## 14. Operating Ambient Humidity

Take note that moisture could lead to power module abnormal operation or damage.

## 15. Storage Ambient Temperature

Abrupt temperature change would cause moisture formation that leads to poor solderability of each terminal of the power module.

## 16. Storage Ambient Humidity

Take enough care when storing the power module because rust which causes poor solderability would form in each terminal when stored in high temperature, high humidity environment.

## 17. Cooling Method

Operating temperature range is specified by the baseplate temperature. Therefore, several methods of heat dissipation are possible.

For details on thermal design, refer to Application Notes “Thermal Design”.

## 18. Baseplate Temperature vs. Output

### Voltage Drift

Output voltage drift is defined as the rate of voltage change when baseplate temperature only is changed during operation.

## 19. Withstand Voltage

This power module is designed to have a withstand voltage of 3kVAC between input and output, 1.5kVAC between input and baseplate and 500VAC between output and baseplate for 1 minute. When conducting withstand voltage test during incoming inspection, set the current limit value of the withstand voltage testing equipment to 20mA.

Furthermore, avoid throw in or shut off of the testing equipment when applying or when shutting down the test voltage. Instead, gradually increase or decrease the applied voltage. Take note especially not to use the timer of the test equipment because when the timer switches the applied voltage off, impulse voltage which has several times the magnitude of the applied voltage is generated causing damage to the power module.

Connect the terminals as shown in the diagram below.

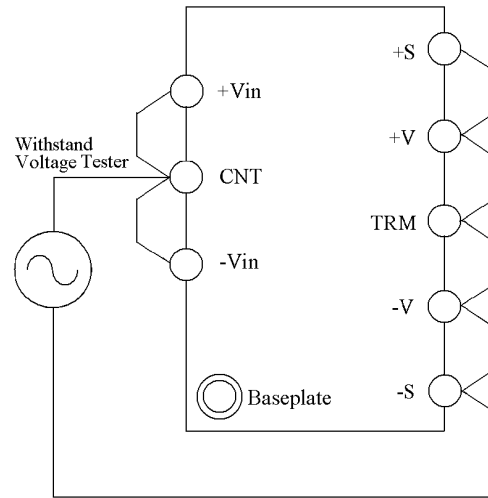

**3kVAC 1 minute**

**Fig.19-1 Withstand Voltage Test for Input - Output**

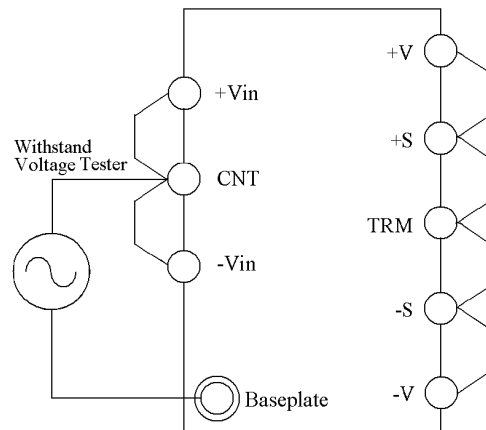

**1.5kVAC 1minute**

**Fig.19-2 Withstand Voltage Test for Input - Baseplate**

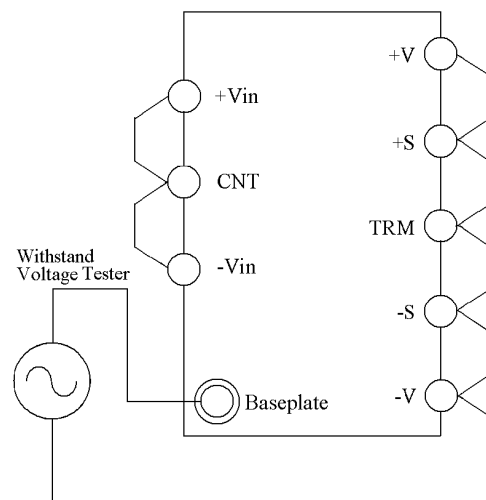

**500VAC 1minute**

**Fig.19-3 Withstand Voltage Test for Output - Baseplate**

## Withstand Voltage Testing with Attached External Application

As shown in Fig. 19-4, take note that for applications that require additional components C4, C5, C6, C7 to Fig. 1-2 as noise countermeasure, there is need to set capacitance ratio to satisfy Withstand Voltage test of 3kVAC between input and output. Capacitance ratio should be  $C4, C5 : C6, C7 = 1:1.3 - 1.5$ .

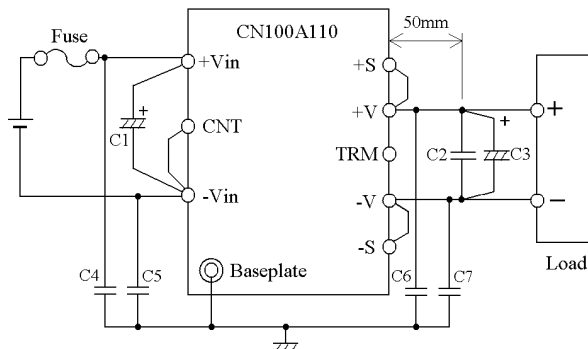
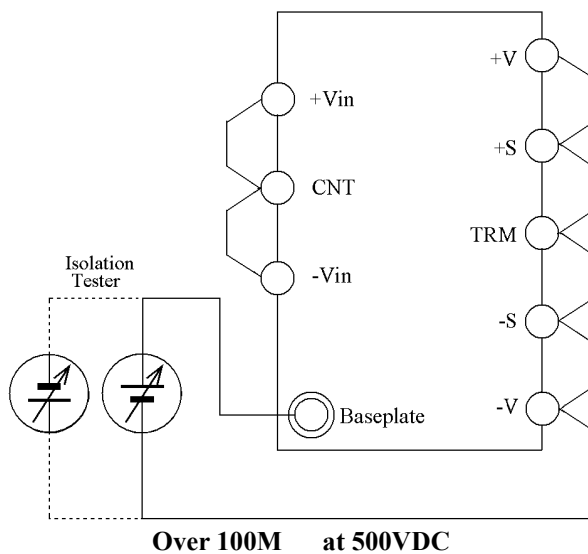

**Fig.19-4**Example of External Application for Noise Countermeasure

## 20. Isolation Resistance

Use DC insulation tester (MAX 500V) between output and baseplate. Insulation resistance value is 100MΩ and above at 500VDC applied voltage.

Make sure that during testing, the isolation testers does not produce a high pulse when the applied voltage is varied. Ensure that the tester is fully discharged after the test.



**Fig.20-1** Isolation Test

## 21. Vibration

Vibration of power module is defined in case of mounting on printed circuit board.

## 22. Shock

Withstand shock value is defined to be the value at TDK -Lambda shipment and packaging conditions.

## Installation

### 1. Mounting Method

By the following instruction shown in Fig.1-1, mount power module onto printed circuit board.

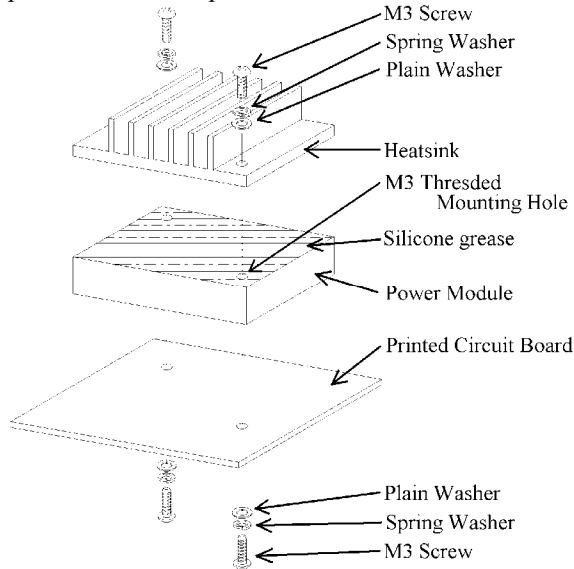

Fig.1-1 Mounting method

#### (1) Method to Fix

To fix a power module onto printed circuit board, use M3 screws and mount it to the M3 threaded holes (2places) of the power module. Recommended torque is 0.54N·m.

#### (2) Mounting Holes

Mounting holes of the power module are connected to baseplate. Connect baseplate to FG (Frame Ground) by using this mounting holes.

#### (3) Mounting Holes on Printed Circuit Board

Refer to the following sizes when determining diameter of hole and land diameter of printed circuit board.

Input / Signal terminals ( 1.0 mm )	
Hole diameter	: 1.5 mm
Land diameter	: 2.5 mm
Output terminals ( 1.5 mm )	
Hole diameter	: 2.0 mm
Land diameter	: 3.0 mm
Mounting Holes (FG)	
Hole diameter	: 3.5 mm
Land diameter	: 5.5 mm

For position of the holes, see outline drawing of the

power module.

#### (4) Recommended Material of PCB

Recommended materials of the printed circuit board is double sided glass epoxy with through holes. (thickness t:1.6mm , copper 35 μ m).

#### (5) Input / Output terminal pin

Connect +Vin, -Vin, +V, -V terminals such that contact resistance is minimal. Note that if contact resistance is high, efficiency will drop and power module will be damaged by abnormal heat.

#### (6) Input / Output Pattern Width

Large current flows through input and output pattern. If pattern width is too narrow, heat on pattern will increase because of voltage drop of pattern. Relationship between allowable current and pattern width varies depending on materials of printed circuit board, thickness of conductor. It is definitely necessary to confirm on manufacturers of printed circuit board for designing pattern.

## 2. Heatsink Installation Method

### (1) Method to Fix

To fix the heatsink onto power module, use M3 screws and mount it to the M3 threaded holes (2 places) at the baseplate side. Recommended torque is 0.54 N·m.

Use silicone grease or thermal conductive sheet in between heatsink and baseplate to minimize the contact thermal resistance and to enhance the heat conductivity. Also use the no-warped heatsink and make sure good contact between baseplate and heatsink.

### (2) Mounting Hole of Heatsink

Recommended mounting hole is as follows.  
3.5 Non-threaded hole

### 3. Regarding Vibration

The vibration specification of the module is determined assuming that only the power module is mounted on printed circuit board. To prevent excessive force to the module and the printed circuit board, fix the heatsink to the chassis as well as to the module when a large size of heatsink is used.

### 4. Recommended Soldering Method

Recommended soldering conditions are as follows.

#### (1) Soldering dip

Dip condition : 260°C within 10 seconds

Pre-heat condition : 120°C within 60 seconds

#### (2) Soldering iron

350°C within 3 seconds

Soldering time changes according to heat capacity of soldering iron, pattern on printed circuit board, etc. Please confirm actual performance.

### 5. Recommended Cleaning Condition

Recommended cleaning condition after soldering is as follows.

#### (1) Cleaning solvent

IPA (isopropyl alcohol )

#### (2) Cleaning Procedure

Use brush and dry the solvent completely.

## **Before concluding power module damage**

Verify following items before concluding power module damage.

- 1) No output voltage
  - Is specified input voltage applied?
  - Are the ON/OFF control terminal (CNT), remote sensing terminal (+S, -S), output voltage trimming terminal (TRM) correctly connected?
  - For cases where output voltage adjustment is used, is the resistor or variable resistor setting, connections correctly done?
  - Are there no abnormalities in the output load used?
  - Is the baseplate temperature within the specified temperature range?
- 2) Output voltage is high
  - Are the remote sensing terminals (+S, -S) correctly connected?
  - Is the measurement done at the sensing points?
  - For cases where output voltage adjustment is used, is the resistor or volume setting, connections correctly done?
- 3) Output voltage is low
  - Is specified input voltage applied?
  - Are the remote sensing terminals (+S, -S) correctly connected?
  - Is the measurement done at the sensing points?
  - For cases where output voltage adjustment is used, is the resistor or variable resistor setting, connections correctly done?
  - Are there no abnormalities in the output load used?
- 4) Load regulation and line regulation is large
  - Is specified input voltage applied?
  - Are the input terminals and the output terminals firmly connected?
  - Is the measurement done at the sensing points?
  - Is the input or output wire too thin?
- 5) Output ripple voltage is large
  - Is the measuring method used the same or equivalent with the specified method in the Application Notes?
  - Is the input ripple voltage value within the specified value?